

TP340 TP Castlewood Tower



INSTRUCTIONS FOR ASSEMBLY MAINTENANCE AND USE



Important!

These instructions must be followed for safe assembly and use.
Please retain for future reference.

Important!

Vous devez suivre ces instructions pour que le montage et l'utilisation se fassent en toute sécurité. Veuillez conserver pour référence ultérieure.

Importante!

Per garantire sicurezza di montaggio ed uso, seguire queste istruzioni e conservarle per futuro riferimento.

Importante!

Debe seguirse estas instrucciones para un armado y uso seguros.
Sirvase conservarlas para consultarlas en el futuro.

Wichtig!

Diese Anweisung ist für sicheren Aufbau und Gebrauch zu befolgen.
Für künftigen Gebrauch aufbewahren.

Importante!

Para assegurar uma montagem e uma utilização seguras, têm de ser seguidas estas instruções. Guardar para referência futura.



WARNING

TOY MUST BE ASSEMBLED BY
AN ADULT BEFORE USE.

Children must not use the
equipment until properly installed.



Assembly Build

**WARNING only for domestic use
Outdoor use**

Important!
Age 3-10 yrs

GB

1. ASSEMBLY AND SAFETY INFORMATION

INSTRUCTIONS FOR ASSEMBLY, MAINTENANCE AND USE OF TP TOYS -

Please read carefully and keep all enclosed information for future reference.

TP toys must be assembled by an adult. They must be erected exactly in accordance with the assembly instructions. Enlisting the aid of a helper will make assembly easier. In order to ensure the correct tensions and to ease assembly, it is important to assemble the product hand tight to begin with. Only when complete, should the fastenings be fully tightened and checked. This pack may contain small parts and is not suitable for children under 36 months. We recommend that you place small parts on a tray, or something similar, to prevent the frustration and disappointment of mislaying them. Please take care during assembly as the manufacturing process can sometimes result in the occasional sharp edge and small pieces of waste metalwork. General instruction to kit/accessory about installation of rope/nets (in relation with the diameter fixed at both ends, length of pending, interaction with other structure. Should there be any missing parts, the toy must not be used until replacement parts have been fitted - the TP Customer Services: Email: customerservices@tp toys.com

2. SITING

Under no circumstances should any of our toys be positioned on a hard surface such as concrete or asphalt, unless the ground under the toy plus the recommended freespace area is covered with a safety surface. Examples of suitable surfaces are grass, sand or a play surface intended for this use. TP toys should be sited on level ground.

3. USAGE

TP toys are designed and made for use only by children aged between 36 months and 10 years, unless otherwise stated, and must not be used by anybody else. Misuse can result in injury. TP tents must not be walked or climbed upon. "Warning only for Domestic use." For outdoor use only.

4. SUPERVISION

Children should always be supervised while they are playing on TP toys and should be instructed not to use the toy in an inappropriate or hazardous manner. We recommend that they do not wear loose-fitting clothing or jewellery that may catch or snag during play. Children should not wear cycle helmets while playing on TP toys. Whilst using this swing seat children must have constant adult supervision.

5. WEATHER CONDITIONS

Special care should be taken as weather conditions change. In particular, outdoor toys can become slippery in wet weather and tongues and lips can stick to metalwork at subzero temperatures. In warmer and sunnier weather, parts can become hot, and the temperature should be regularly checked during play, especially metal parts and slides. If there is any doubt over safety then the toys should not be used. If high wind is expected or forecasted, please ensure that the outdoor toys are either moved to a sheltered position or well secured to the ground or other immovable object. Please store plastic swing accessories indoors if temperature falls below 40°F (4°C).

6. WATER PLAY

Many surfaces can become slippery during water play. Extra caution and supervision is required when combining water (e.g. paddling pools, aqua slides etc.) with other forms of outdoor play.

7. MAINTENANCE

With all toys it is vital that the equipment is checked regularly and often by an adult. The complete toy should be checked at least once a month, and particular attention should be paid to connections and fastenings. If any parts exhibit signs of wear and tear, they may need to be replaced. To replace defective parts in accordance with the manufacturer's instructions. Checks must be carried out at the beginning of the usage season as well as at regular intervals throughout the usage season. Check all nuts and bolts for tightness and tighten when required. Failure to do this may result in the product malfunctioning and causing injury. Children must not be allowed to use the toy until properly installed and checked. Galvanised tubular products may require occasional maintenance. If surface rust appears it should be removed with either a wire brush or coarse sandpaper, and the area treated with a non-toxic paint. Changes to the original toy (for example the adding of an accessory) shall be carried out according to the instructions of the retailer of the original toy.

8. FIRE RISKS AND DISPOSAL

Never allow TP toys to be placed or used near a fire. When it becomes necessary to dispose of your equipment, remove all bolts and disassemble. Store out of the reach of children until it can be properly disposed of. These instructions are issued in the interest of child safety, and we do ask you to follow our advice.

9. SWINGING TOYS

When fitting swinging toys it is vital that moving parts have no metal to metal contact. Children should be instructed not to pass in front of or behind moving items, not to twist or swing an empty swing seat, and not to get off a swinging toy when it is in motion.

10. ROPES

These ropes will degrade over time. When signs of degradation appear, the toy should be replaced.

INSTRUCTIONS CONCERNANT L'ASSEMBLAGE, L'ENTRETIEN ET L'UTILISATION DE MATÉRIEL

TP Veuillez lire attentivement les instructions suivantes et les conserver à des fins de référence future.

1. ASSEMBLAGE ET SECURITE

L'assemblage des équipements/jouets TP doit être uniquement effectué par un adulte. Le montage doit être fait en suivant rigoureusement les étapes des instructions fournies. L'aide d'une seconde personne peut grandement faciliter l'assemblage. Afin d'assurer les tensions correctes et pour faciliter le montage, il est important d'assembler le produit en serrant à la main pour commencer. Ce n'est qu'un fois le montage terminé que les fixations devront être serrées à fond et vérifiées. Veuillez vous assurer que toutes les fixations sont bien serrées avant d'utiliser l'installation. Cet équipement ne convient pas à des enfants de moins de 3 ans car il comporte de petits éléments pouvant être avalés ou inhalés. Afin d'éviter les risques de perte de certaines pièces de taille réduite, il est conseillé de les disposer sur un plateau ou sur un support du même genre. Lors de l'assemblage, il est recommandé de manipuler les pièces avec précaution car celles-ci peuvent présenter des aspérités résultant du procédé de fabrication. S'il manque des pièces, ne pas utiliser le matériel tant que la ou les pièces en question n'ont pas été montées. Service Clients TP: Email customerservices@tp toys.com

2. INSTALLATION

Notre matériel ne doit en aucun cas être installé sur des surfaces en dur (béton, asphalte, etc.) à moins que la surface du sol sous le matériel (plus la marge de sécurité recommandée à l'extérieur du périmètre total du matériel) ne soit recouverte d'un revêtement de sécurité. Il est recommandé d'installer le matériel sur de l'herbe ou du sable ou une aire recouverte d'un revêtement de sécurité approprié. Les équipements TP doivent être installés sur une surface plane.

3. UTILISATION

Nos équipements/jouets sont destinés à l'usage familial et ont été conçus, sauf mention spéciale, à l'intention des enfants entre 36 mois et 10 ans; ils ne doivent EN AUCUN CAS être utilisés par d'autres personnes. Nos équipements/jouets sont entièrement sûrs s'ils sont utilisés conformément aux présentes instructions. Il ne faut pas marcher ou grimper sur les tentes "TP".

4. SUPERVISION

La supervision permanente d'un adulte est nécessaire lors de l'utilisation des équipements/jouets TP par des enfants. Pour des raisons de sécurité, il est conseillé de s'assurer que les enfants utilisent les équipements/jouets correctement et ne portent pas de casque pour vélo, ni de vêtements lâches ou de bijoux, qui pourraient être retenus ou s'accrocher.

5. UTILISATION ET CONDITIONS METÉOROLOGIQUES

Une prudence accrue est recommandée lors de certaines conditions météorologiques. Les équipements/jouets de plein air deviennent glissants avec la pluie. Lorsqu'il gèle, il est recommandé de faire attention car les lèvres et la langue peuvent "coller" au métal. Par temps chaud et en cas d'exposition au soleil, il convient de vérifier régulièrement si la température de l'équipement/jouet n'est pas trop élevée, spécialement au niveau des éléments métalliques et des toboggans. En cas de doute, il est conseillé d'interdire l'usage du matériel. Si de forts vents sont attendus ou prévus, veuillez vous assurer que les installations de jeux d'extérieur sont soit mises à l'abri, soit bien fixées au sol ou à tout autre objet qui ne peut être déplacé.

6. JEUX AQUATIQUES

Nos équipements/jouets aquatiques peuvent devenir extrêmement glissants, aussi une supervision attentive et une prudence accrue sont recommandées lors d'usage d'équipements de plein air utilisant de l'eau tels que des piscines gonflables, des toboggans aquatiques, etc.

7. ENTRETIEN

Il est essentiel qu'un adulte se charge de contrôler chaque équipement/jouet à intervalles réguliers. L'ensemble de l'équipement/jouet, et en particulier toutes les pièces d'assemblage et les systèmes d'attache, doit être vérifié au moins une fois par mois. Si des pièces présentent des signes d'usure, il convient de remplacer la ou les pièces en question. Dans ce cas, l'équipement/jouet ne devra pas être utilisé tant que la ou les pièces de rechange n'auront pas été montées. Les Produits tubulaires galvanisés nécessiteront éventuellement un entretien occasionnel. Si de la rouille apparaît sur la structure, il convient de l'enlever avec une brosse métallique ou du papier de verre à gros grains, pour ensuite appliquer sur la surface une peinture non toxique.

8. RISQUES D'INCENDIE ET NON-USAGE

Ni jamais placer ou utiliser les équipements/jouets TP à proximité de flammes nues. Si vous devez vous débarrasser d'un équipement/jouet, démontez-le en veillant à enlever toutes les vis. Si ce matériel doit être momentanément entreposé, assurez-vous de le maintenir hors de portée des enfants.

9. BALANÇOIRES, BARRES DE TRAPEZE, ANNEAUX, etc.

Les présentes instructions ont été rédigées pour la sécurité de votre enfant et nous vous demandons de bien vouloir suivre nos conseils. Lors de l'assemblage, il est essentiel de s'assurer qu'il n'existe aucun contact métal/métal sur les pièces mobiles. Pour des raisons de sécurité, il est important d'apprendre aux enfants de ne pas passer devant ou derrière des balançoires en mouvement, de ne pas sauter d'une balançoire en mouvement et de ne pas faire aller une balançoire à vide ou l'utiliser comme une "ville". Concernant la marge de sécurité recommandée.

10. CORDAGES

Avec le temps, les cordages auront tendance à se dégrader. En cas de signes d'usure des cordages, il convient de remplacer le jouet ou l'équipement en question.

I

1. INFORMAZIONI DI MONTAGGIO E SICUREZZA

ISTRUZIONI DI MONTAGGIO, MANUTENZIONE E UTILIZZO DEI GIOCHI TP

Leggere attentamente tutte le seguenti informazioni e conservarle per riferimento futuro.

I giochi TP devono essere montati da un adulto. Devono essere eretti seguendo esattamente le istruzioni di montaggio fornite. La procedura di montaggio viene facilitata se si fa ricorso all'assistenza di un'altra persona. Per garantire la corretta messa in tensione e facilitare l'assemblaggio, è importante montare questo prodotto serrandolo inizialmente solo a man. Serrare solo alla fine completamente e controllare tutti i dispositivi di fissaggio. Assicurarsi che tutti i dispositivi di fissaggio siano serrati bene prima dell'uso. Questa confezione può contenere pezzi piccoli e il suo contenuto, non è adatto per i bambini di età da 3 anni di età. Si raccomanda di mettere i pezzi più piccoli in un vassoio o in un recipiente simile per evitare frustrazione e disappunto, o di perderli. Prestare particolare attenzione durante il montaggio del gioco, dato che il processo di fabbricazione può lasciare talvolta spigoli taglienti e pezzetti di metallo sciolti di scarto. Se dovessero per caso mancare dei pezzi, non usare il gioco prima di avere montato i pezzi mancanti di ricambio. Per la linea del Servizio Clienti TP: Email customerservices@tp toys.com

2. POSIZIONAMENTO DEI GIOCHI

Non posizionare in alcun caso i giochi su superfici dure come quelle di calcestruzzo o di asfalto, a meno che il terreno sotto il gioco e lo spazio libero circostante raccomandato siano coperti con una superficie di sicurezza. Superfici di tipo adatto sono quelle erbose, sabbiose o per giochi intese per tale uso. I giochi TP devono essere posizionati su terreno in pari. Non camminare e non arrampicarsi sulle tende "TP".

3. UTILIZZO

A meno che sia indicato altrimenti, i giochi TP sono progettati e costruiti per essere usati dai bambini di età fra 36 mesi e 10 anni, e non devono essere usati da altre persone. Un cattivo uso può provocare lesioni personali. Non camminare e non arrampicarsi sulle tende "TP".

4. SORVEGLIANZA

I bambini devono essere sempre sorvegliati quando si divertono con i giochi TP, ed è necessario insegnare loro a non usare i giochi in maniera incorretta o pericolosa. Si raccomanda che i bambini non indossino indumenti sciolti o articoli di gioielleria che durante il gioco possono restare impigliati o agganciati. I bambini non devono indossare caschi per bicicletta quando si divertono con i giochi TP.

5. CONDIZIONI ATMOSFERICHE

Prestare particolare attenzione al cambiare delle condizioni atmosferiche, dato che con la stagione bagnata le superfici possono diventare scivolose. Quando la temperatura è sotto zero le labbra e la lingua possono aderire alle parti di metallo, mentre nella stagione calda e soletta i vari elementi dei giochi possono diventare molto caldi; bisogna controllarne perciò con regolarità la temperatura, specialmente quella dei componenti metallici e degli scivoli. Non usare i giochi se sussiste alcun dubbio sulla loro sicurezza. Se si ci si aspettano o si prevedono venti forti, assicurarsi che i giochi installati all'aperto siano trasferiti in una posizione protetta, oppure assicurarsi che siano trasferiti in una posizione protetta, oppure assicurarsi che siano fissati saldamente al terreno o ad altri oggetti che non possono muoversi.

6. GIOCHI CON L'ACQUA

Nel giochi con l'acqua, molte superfici possono diventare scivolose. Quando ad altre forme di giochi all'aperto si abbina l'acqua (come ad esempio nelle piscine basse per bambini piccoli, negli scivoli ad acqua, ecc.) bisogna essere particolarmente attenti ed esercitare stretta sorveglianza.

7. MANUTENZIONE

Come per tutti i giochi, è d'importanza vitale che le attrezzature siano controllate regolarmente e spesso da un adulto. Controllare tutto il gioco almeno una volta al mese, prestando particolare attenzione alle connessioni e ai dispositivi di fissaggio. Se qualsiasi parte presenta segni di deterioramento o di usura, può essere necessario cambiarla. Mancando di farlo si può provocare il cattivo funzionamento del prodotto e produrre lesioni personali. Non lasciare che i bambini usino questo gioco prima che sia stato installato nel modo dovuto e controllato attentamente. I prodotti tubolari in acciaio zincato possono richiedere manutenzione occasionale. Se appare ruggine sulla loro superficie, rimuovetela usando una spazzola metallica o tela smeriglio grossa, e trattare poi l'area interessata con una vernice non tossica.

8. RISCHI E PROCEDURE PER L'ELIMINAZIONE

Non permettere mai che i giochi TP siano posizionati od usati vicini al fuoco. Quando diventa necessario disfarsi dei giochi, rimuovere tutti i bulloni e smontarli, tenendoli fuori della portata dei bambini fino a quando possono essere eliminati nel modo dovuto.

9. GIOCHI AD OSCILLAZIONE

Queste istruzioni sono preparate nell'interesse della sicurezza dei bambini e si raccomanda di seguire tutti i consigli ivi contenuti. Nel montare i giochi ad oscillazione, è d'importanza vitale che le parti in movimento non abbiano elementi di metallo in contatto con altre parti metalliche. Insegnare ai bambini a non passare davanti o dietro gli oggetti in movimento, a non fare ruotare od oscillare i sedili delle altalene vuoti, e a non scendere dai giochi ad oscillazione prima che si siano fermati.

10. FUNI

Con l'andare del tempo queste funi si deteriorano. Cambiare il gioco non appena appaiono segni di deterioramento.

E

INSTRUCCIONES DE MONTAJE, MANTENIMIENTO Y USO DE LOS JUGUETES TP**Lea detenidamente toda la información adjunta y consérvela para futuras consultas.****1. INFORMACIÓN SOBRE MONTAJE Y SEGURIDAD**

Los juguetes TP deben ser montados por un adulto. Deben armarse siguiendo fielmente las instrucciones de montaje, y será más fácil hacerlo con la ayuda de otro adulto. A fin de asegurar las tensiones correctas y para que el armado sea fácil, es importante armar el producto solamente a mano para comenzar. Sólo cuando esté terminado, deberían ajustarse los fijadores completamente y ser verificados. Asegúrese por favor de que todos los fijadores estén firmes o apretados antes de usar el juego. Este paquete puede incluir piezas pequeñas, por lo que no es apropiado para niños menores de 3 años. Recomendamos que coloque las piezas pequeñas en una bandeja o recipiente similar, para evitar la frustración de no saber dónde las ha puesto. Tenga cuidado durante el montaje, ya que tras el proceso de fabricación pueden aparecer a veces bordes afilados y pequeños restos metálicos. Si falta alguna pieza, el juguete no debe usarse hasta que se hayan procurado las piezas de repuesto. El teléfono de atención al cliente de TP es: Email customerservices@tptoys.com

2. EMPLAZAMIENTO

Nuestros juguetes no deben, en ningún caso, colocarse sobre una superficie dura, por ejemplo de cemento o asfalto, a menos que el suelo bajo el juguete y la zona libre recomendada estén cubiertos con una superficie segura. Algunos ejemplos de superficies aptas serían de hierba, arena o superficies de juego preparadas para este propósito. Los juguetes TP deben emplazarse en suelo llano.

3. USO

Los juguetes TP están diseñados y fabricados para niños de entre 36 meses y 10 años, a menos que aparezca otra indicación, y no deben ser usados por personas de otras edades. El uso inapropiado de estos productos puede causar daños personales. No debe caminar por encima de las carpas "TP" ni treparse por ellas.

4. SUPERVISIÓN

Mientras jueguen con los juguetes TP, los niños deben ser supervisados, y se les debe advertir que no deben usarlos de un modo inadecuado o peligroso. Recomendamos que no lleven prendas muy amplias o adornos que se puedan enganchar mientras juegan. No deben llevar cascos de ciclista cuando juegan con juguetes TP.

5. CONDICIONES METEOROLÓGICAS

Durante los cambios meteorológicos se deben tomar mayores precauciones. En concreto, los juguetes para exteriores pueden resultar resbalosos en la lluvia, y los labios y la lengua pueden pegarse al metal a temperaturas inferiores a los 0°C. En días calurosos y soleados, puede que algunas piezas se recalienten, por lo que la temperatura del juguete debe comprobarse con frecuencia mientras se usa, especialmente las piezas metálicas y los toboganes. En caso de albergar alguna duda sobre la seguridad del uso del juguete, deben abstenerse de usarlo. Si se esperan o han sido pronosticados vientos fuertes, por favor verifique que los juegos de exteriores sean trasladados a un lugar protegido o que sean fijados en forma segura al suelo o a otro objeto fijo.

6. JUEGOS DE AGUA

Muchas superficies pueden volverse resbalosas cuando se juega en el agua. Se debe prestar un mayor cuidado y una supervisión más estricta cuando se combina el agua (por ejemplo, una piscina inflable, toboganes acuáticos, etc.) con otras formas de jugar al aire libre.

7. MANTENIMIENTO

En el caso de todos los juguetes, es de suma importancia que el equipo sea revisado con bastante regularidad por un adulto. El juguete completo debería ser revisado al menos una vez al mes, prestando especial atención a las conexiones y las sujeciones. Si alguna pieza presenta señales de desgaste o rotura, puede que necesite ser reemplazada. De no hacerlo, puede que el producto deje de funcionar correctamente y que cause un daño. No se debe permitir que los niños usen el juguete hasta que esté instalado y haya sido revisado. Los productos tubulares galvanizados pueden necesitar trabajos de mantenimiento ocasionales. Si aparece óxido en la superficie, debe quitarse con un cepillo de alambre o con papel de lija grueso, y se debe tratar la zona con una pintura no tóxica.

8. PELIGRO DE INCENDIO Y CÓMO TIRAR EL JUGUETE

Nunca permita colocar o usar un juguete TP cerca del fuego. Llegado el momento de tirar el equipo, retire todos los tornillos y desmóntelo. Guárdelo fuera del alcance de los niños hasta el momento de deshacerse del mismo.

Estas instrucciones se facilitan para la seguridad del niño. Le rogamos que siga nuestros consejos.

9. JUGUETES DE COLUMPIAR

Cuando se instalan los juguetes de columpiar, es de suma importancia que las piezas móviles metálicas no tengan contacto entre sí. Se debe advertir a los niños que no deben pasar por delante o por detrás de los columpios, ni retorcer o balancear los asientos vacíos, ni bajarse de ellos cuando están en movimiento.

10. CUERDAS

Estas cuerdas se desgastarán con el tiempo. Cuando aparezcan síntomas de desgaste, se deberá reemplazar el juguete.

D

ANLEITUNG ZUR MONTAGE, WARTUNG UND GEBRAUCH VON TP SPIELGERÄT**Bitte lesen Sie diese Anleitung vor der Montage und der ersten Benutzung sorgfältig durch.****Bitte bewahren Sie diese Anleitung zur Information, bzw. für Wartungsarbeiten und Ersatzteilbeschaffung auf.****1. MONTAGE**

Dieses Spielgerät muß durch einem Erwachsene aufgebaut werden. Befolgen Sie dabei genau die Bauanleitung. Das ergebnis soll zuerst nur fingerfest verschraubt werden, um sicher zu stellen, dass es sich nicht verzieht und um den zusammenbau zu erleichtern. Erst nachdem alle teile zusammen gebaut sind, sollten sie fest angezogen und überprüft werden. Stellen sie sicher, dass alle befestigungen vor gebrauch fest angezogen sind. Dieser Artikel enthält Kleinteile und ist daher Nicht für Kinder unter 36 Monaten geeignet. Bitte achten Sie auf scharfkantige Bohrungen und Späne, die unter Umständen in der Herstellung dieses Spielgerätes anfallen können. Sollten Einzelteile fehlen, so darf das Spielgerät nicht benutzt werden. Bitte sorgen Sie dafür, daß die notwendigen Ersatzteile montiert werden. Sie können Einzelteile beim TP Kundenservice: Email customerservices@tptoys.com

2. STANDORT

Unsere Spielgeräte dürfen unter keinen Umständen auf hartem Untergrund (Asphalt oder Beton) aufgestellt werden und sollte ebenerdig sein. Der Standort muß so gewählt werden, daß ausreichende Sicherheitsabstände gewährleistet sind.

3. VERWENDUNGSBEREICH

Verwendungsbereich - Dieses Spielgeräte dürfen nur bestimmungsgemäß verwendet werden, d.h. als Kinderspielgerät im ausschließlich privaten Garten für eine dem Gerät angemessene Anzahl von Kindern von 36 Monaten bis 10 Jahre alt. Jegliche andere Verwendung ist unzulässig und möglicherweise gefährlich. TP Activity Toys übernimmt keine Haftung für Schäden, die aus nicht zweckgemäßen Gebrauch entstehen.

4. BEAUFSICHTIGUNG

Kinder sollten nur unter Beaufsichtigung von Erwachsenen mit TP Spielgeräten spielen und sollten über den zweckmäßigen Gebrauch unterrichtet werden. Wir empfehlen, daß Kinder keine lose Kleidung oder Schmuck beim Spielen tragen, außerdem dürfen keine Fahrradhelme getragen werden.

5. WETTEREINFLÜSSE

Achten Sie darauf, daß unser Spielzeug, vor allem die Plastik- und Metallteile, ganzjährig allen Wetterbedingungen ausgesetzt ist. Stellen Sie sicher, daß unter widrigen Bedingungen nicht mit dem Spielgerät gespielt wird. Wenn starker wind erwartet oder vorhergesagt wird, stellen sie bitte sicher, dass die spielzeuge im freien entweder unter schutz gestellt werden oder am grund oder einem festen punkt fest gezurt werden.

6. SPIELEN MIT WASSER

Beim Spielen in Verbindung mit Wasser (Planschbecken, Wasserutsche, usw.) sollte besondere Vorsicht geboten sein, da das Spielgerät sehr rutschig werden kann. Es ist für Spielzeug im allgemeinen notwendig, daß Kleinteile und Verbindungen von einem Erwachsenen in regelmäßigen Abständen auf ihre Funktionstüchtigkeit überprüft werden. Führen Sie in monatlichen Abständen, dem Spielbetrieb angemessen, regelmäßige Kontrollen aller Schraub- und anderen Verbindungen durch. Ein nicht angemessenes Überprüfen des Zustandes, kann die Lebensdauer des Spielgerätes verringern und die Sicherheit Ihrer Kinder gefährden.

7. WARTUNG

Verschlossene Teile sollten frühzeitig ersetzt werden. Zink galvanisierte Teile können unter Umständen Roststellen aufweisen. Sie sollten diese mit einer Drahtbürste behandeln und mit ungiftiger Schutzfarbe überstreichen.

8. ENTSORGUNG

Bevor Sie Ihr Gerät entsorgen, entfernen Sie alle Schraubverbindungen und lagern es so, daß Kinder keinen Zugriff auf einzelne Teile haben.

Es ist ratsam, die Kleinteile während der Montage an einem sicheren Platz aufzubewahren, damit Sie keine Schrauben oder Muttern verlieren. Dieses Spielgerät muß von einem Erwachsenen aufgebaut werden.

9. SCHAUKELSITZE

Bei der Montage von Schaukelsitzen muß darauf geachtet werden, daß unter keinen Umständen Metallteile aufeinander reiben. Kinder müssen unterwiesen werden, nicht hinter oder vor bewegenden Schaukeln zu spielen.

10. SEILE

Seile werden sich durch Gebrauch abnutzen. Es ist daher notwendig, alle Seile in angemessen Abständen nach Funktion und Verschleiß hin zu überprüfen und gegebenenfalls zu ersetzen.

P

INSTRUÇÕES PARA MONTAGEM, MANUTENÇÃO E USO DE BRINQUEDOS**Leia com atenção as informações que se seguem e guarde-as para futuras consultas. Consulte a identificação de peças no esquema das páginas 6.****1. INFORMACÃO A RELATIVA MONTAGEM E SEGURANÇA**

Os brinquedos devem ser montados por adultos e seguindo sempre de forma exacta as instruções de montagem. A montagem poderá ser facilitada pela presença de um ajudante. Para garantir que são exercidas as tensões correctas e para facilitar o processo de montagem, é importante que o produto seja primeiro apertado só à mão. Só quando a montagem estiver concluída, é que se deve apertar totalmente e fazer uma verificação geral. Antes da utilização, certifique-se de que todos os fechos estão bem apertados. Esta embalagem poderá conter peças de pequenas dimensões, não sendo adequada para crianças de idade inferior a 36 meses. Recomendamos que coloque as peças de pequenas dimensões num tabuleiro ou superfície semelhante de modo a que não as perca. Tenha cuidado durante a montagem, já que o processo de fabrico pode por vezes resultar em arestas afiadas e em pequenos pedaços de metal soltos. Caso haja peças em falta, o brinquedo não deve ser usado até que estas sejam obtidas e montadas. A linha de Apoio ao Cliente é Email customerservices@tptoys.com

2. COLOCAÇÃO

Em circunstância alguma devem os nossos brinquedos ser colocados numa superfície rígida, como cimento ou alcatrão, a não ser que a superfície sob o brinquedo e a superfície adicional envolvente recomendada estejam cobertas por uma superfície de segurança. A relva, areia ou superfícies desportivas são exemplos de superfícies adequadas para esta utilização. Os brinquedos devem ser colocados ao nível do chão.

3. UTILIZAÇÃO

Os brinquedos foram concebidos apenas para uso doméstico familiar no exterior e só por crianças com idades entre os 36 meses e os 10 anos, e não devem ser usados por pessoas de outras idades. O não seguimento destas instruções de uso poderá resultar em ferimentos.

4. SUPERVISÃO

As crianças devem ser sempre vigiadas por um adulto enquanto estiverem a brincar nos brinquedos e devem ser ensinadas a não usar o brinquedo de forma inadequada ou perigosa. Recomenda-se que as crianças não usem roupas muito largas, nem peças de bijutaria que possam ficar presas ou emaranhar-se durante a brincadeira. As crianças não devem usar capacetes de bicicleta enquanto brincam nos brinquedos.

5. CONDIÇÕES METEOROLÓGICAS

Devem ser tomadas precauções no caso de as condições meteorológicas se alterarem. Em especial, os brinquedos de exterior podem tornar-se escorregadios em condições chuvosas e, a temperaturas negativas, os lábios podem colar-se ao metal. Em condições meteorológicas mais temperadas e soalheiras, as peças podem aquecer, pelo que a temperatura deve ser verificada com regularidade durante a brincadeira, especialmente no que diz respeito a peças metálicas e cordedças. Caso haja alguma dúvida quanto à segurança de um brinquedo, o mesmo não deverá ser usado. Caso haja previsão de ventos fortes, certifique-se de que os brinquedos de exterior são movidos para uma área resguardada ou que estão bem presos ao chão ou a outros objectos imóveis.

6. BRINCAR COM ÁGUA

Muitas superfícies podem tornar-se escorregadias quando as brincadeiras incluem água. É necessário vigiar e tomar cuidados adicionais ao combinar água (por exemplo, em piscinas insufláveis, escorregões de água, etc.) com outras formas de brincadeiras no exterior.

7. MANUTENÇÃO.

Como todos os brinquedos é essencial que o equipamento seja verificado por um adulto de forma regular e frequente. O brinquedo completo deve ser verificado pelo menos uma vez por mês, dando particular atenção às ligações e fechos. Qualquer peça que exiba sinais de desgaste e muito uso deve ser substituída. O não cumprimento desta regra poderá causar um mau funcionamento do produto e possíveis ferimentos. As crianças não devem ser autorizadas a usar o brinquedo até que este esteja totalmente montado e verificado. Caso apareça ferrugem na superfície, esta deve ser removida com uma escova metálica ou com papel de lixa áspero e a área deve ser tratada com uma tinta não tóxica.

8. RISCOS DE INCÊNDIO E ELIMINAÇÃO

Nunca permita que os brinquedos sejam utilizados ou colocados perto de fogo. Quando chegar a altura de eliminar o equipamento, remova todos os parafusos e desmonte-o. Guarde fora do alcance das crianças até que se possa desfazer do brinquedo de forma adequada.

9. BRINQUEDOS OSCILANTES

Ao montar brinquedos oscilantes, é essencial que as peças móveis não estejam em contacto directo de metal com metal. As crianças devem ser ensinadas a não passar em frente ou por trás de objectos em movimento, a não torcer nem baloiçar um assento de baloiço vazio e a não sair do baloiço enquanto este ainda está em movimento.

10. CORDAS

Estas cordas deterioram-se com o tempo. O brinquedo deve ser substituído logo que apareçam sinais de degradação.







Unlike steel, wood is a natural, organic material and each piece will be unique, bearing its own knots, cracks and variations in colour and, unlike steel, wood will react significantly to changes in atmospheric conditions. Wood will expand and contract as fluctuations of temperature and humidity affect the water content of the cell structure. In warm sunny weather it will shrink and in wet weather it will expand. As these physical changes do not, necessarily, take place uniformly throughout a piece of wood, forces are set up which cause cracks and splits to arise.

It is not necessary to stain your Wooden frame

It is made from selected wood which has been pressure treated. This is a process by which preservatives are forced under pressure into the fabric of the timber to protect it from decay and insect damage. This treatment significantly extends the working life of the timber and enables us to offer a five year guarantee (see back cover).

If you do wish to stain your Wooden frame for aesthetic reasons, please use a water-based stain, which is available from any good DIY store.



À propos du bois

Contrairement à l'acier, le bois est une matière organique naturelle et chaque morceau est unique, possède des nœuds, des fissures et des variations de couleur particuliers et, contrairement à l'acier, le bois est très sensible aux variations atmosphériques. Le bois se dilate et se rétracte sous l'effet des variations de température et d'humidité, lesquelles influencent la teneur en eau de sa structure cellulaire. Il se rétracte sous un climat chaud et ensoleillé et se dilate sous un climat humide. Étant donné que ces changements physiques ne se produisent pas de manière uniforme sur un morceau de bois, les forces entrant en jeu dans le processus entraînent la formation de fissures et de fentes.

Il n'est pas nécessaire de teindre le cadre en bois

Celui-ci est constitué de pin sélectionné traité sous pression. Il s'agit d'un procédé selon lequel des agents de conservation du bois sont injectés sous pression dans la structure du bois afin de protéger celui-ci contre la pourriture et les dommages causés par les insectes. Ce traitement allonge considérablement la durée de vie du bois et nous permet d'offrir une garantie de cinq ans (voir au dos du manuel).

En cas de teinture du cadre en bois pour des raisons esthétiques, utiliser une teinture à base d'eau, disponible auprès de tout magasin de bricolage.

Informazioni sul legno

A differenza dell'acciaio, il legno è un materiale naturale, organico e ogni pezzo è unico, con i propri nodi, incrinature e variazioni di colore. Inoltre, a differenza dell'acciaio, il legno reagisce notevolmente ai cambiamenti delle condizioni atmosferiche. Il legno si espande e si contrae quando le variazioni di temperatura e umidità condizionano il contenuto di acqua presente nella struttura delle cellule. In caso di tempo soleggiato e caldo si contrae, in condizioni umide, si espande. Poiché questi cambiamenti fisici non interessano necessariamente in modo uniforme tutto il pezzo di legno, si instaurano forze che provocano incrinature e spaccature.

Non è necessario trattare con mordenti la struttura in legno

È costituita da legno di pino selezionato sottoposto a trattamento a pressione. In tale processo, le vernici protettive vengono spinte sotto pressione nella struttura del legname per proteggerlo dalla decomposizione e dai danni provocati dagli insetti. Questo trattamento estende notevolmente la durata del legname e ci consente di offrire una garanzia di cinque anni (vedi quarta di copertina).

Se si desidera trattare con mordenti la struttura in legno per motivi estetici, utilizzare un mordente ad acqua, disponibile nei migliori negozi di bricolage.

Qué debe saber sobre la madera?

A diferencia del acero, la madera es un material natural y orgánico y cada pieza será única, con sus particulares nudos, grietas y variaciones en el color; además, a diferencia del acero, la madera reaccionará de manera significativa a los cambios en las condiciones atmosféricas. La madera se expandirá y se contraerá ya que las oscilaciones de temperatura y humedad afectan al contenido en agua de la estructura de las células. En los meses más cálidos, se encogerá y, en los más húmedos se dilatará. Puesto que estos cambios físicos no tienen lugar necesariamente de forma uniforme en toda la madera, surgen fuerzas que causan la aparición de grietas y hendiduras.

No es necesario teñir su estructura de madera

Este producto se ha fabricado a partir de madera de pino seleccionada que ha sido sometida a un tratamiento a presión. Este es un proceso por el cual los conservantes se introducen a presión en el tejido de la madera con el propósito de protegerla contra el desgaste y el ataque de insectos. Este tratamiento alarga de manera significativa la vida útil de la madera y nos permite ofrecer una garantía de cinco años (ver contraportada).

Si desea teñir su estructura de madera por motivos estéticos, utilice un tinte de base acuosa, que podrá adquirir en cualquier tienda de bricolaje especializada.

Holz kennen

Im Gegensatz zu Stahl ist Holz ein natürliches, organisches Material, jedes Teil ist einzigartig mit seinen Ästen, Rissen und Farbveränderungen, und anders als Stahl reagiert Holz sehr auf atmosphärische Veränderungen.

Holz zieht sich zusammen und dehnt sich aus gemäß Änderungen der Temperatur und Luftfeuchtigkeit, die den Wasserstand in der Zellstruktur beeinflussen. Bei warmem, sonnigem Wetter schrumpft es zusammen, bei nassem Wetter dehnt es sich aus. Da diese körperlichen Änderungen nicht unbedingt gleichmäßig in einem Stück Holz auftreten, entstehen Kräfte, die Risse und Splitter verursachen.

Es ist nicht notwendig, den Holzrahmen zu beizen

Er ist aus ausgewähltem Kiefernholz, das druckbehandelt wurde. Bei diesem Verfahren wird Holzschutzmittel unter Hochdruck in das Holz eingegeben, um es gegen Fäulnis und Insektschaden zu schützen. Diese Behandlung verlängert deutlich die Standzeit des Holzes und ermöglicht es uns, eine Fünf Garantie zu geben (siehe Rückseite).

Wenn Sie Ihre Holzrahmen aus ästhetischen Gründen beizen möchten, nehmen Sie dafür bitte eine auf Wasser basierende Beize, die in allen guten Heimwerkermärkten erhältlich ist.

Conhecer a madeira

Ao contrário do metal, a madeira é um material natural e orgânico, o que faz com que cada peça seja única, com nós, rachas e variações de cor próprias. Também ao contrário do metal, a madeira reage significativamente às mudanças atmosféricas. A madeira expande e contrai em conformidade com as flutuações da temperatura e humidade, as quais afectam o conteúdo de água na sua estrutura molecular. Em dias quentes e solarengos, a madeira encolhe, e em dias de chuva, expande. Como estas alterações físicas não ocorrem necessariamente de um modo uniforme por todo um pedaço de madeira, dão-se tensões que provocam o aparecimento de fendas e rachas.

Não é necessário tingir a estrutura de Madeira

A estrutura é concebida em madeira seleccionada que foi submetida a um tratamento de pressão. Este é um processo no qual, através de pressão, se força a entrada de conservantes no tecido da madeira para a proteger contra o apodrecimento e danos provocados por insectos. Este tratamento aumenta significativamente a vida útil da madeira e permite-nos oferecer-lhe uma garantia de cinco anos (ver atrás).

Caso pretenda tingir a estrutura de Madeira por razões estéticas, por favor utilize um corante à base de água, que poderá adquirir em qualquer loja de bricolage.

Instruction Guide

Read Instructions Before Starting

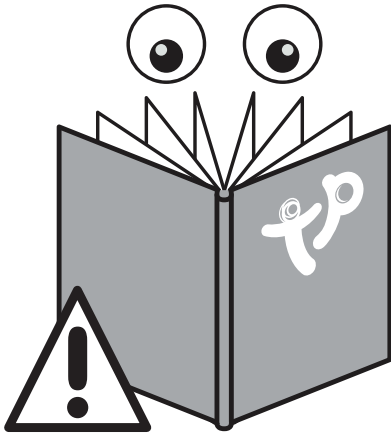

Hidden Lines

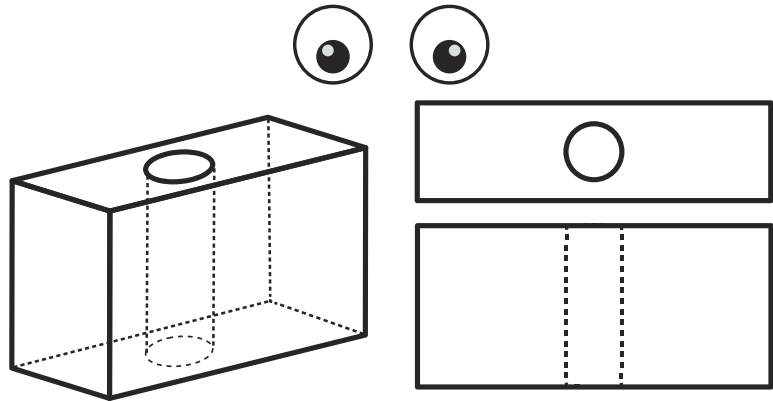

Sort Fixings

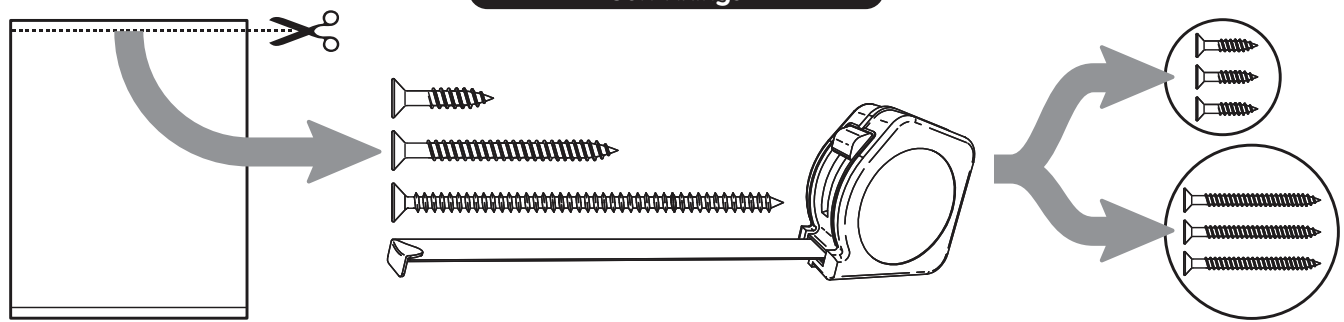



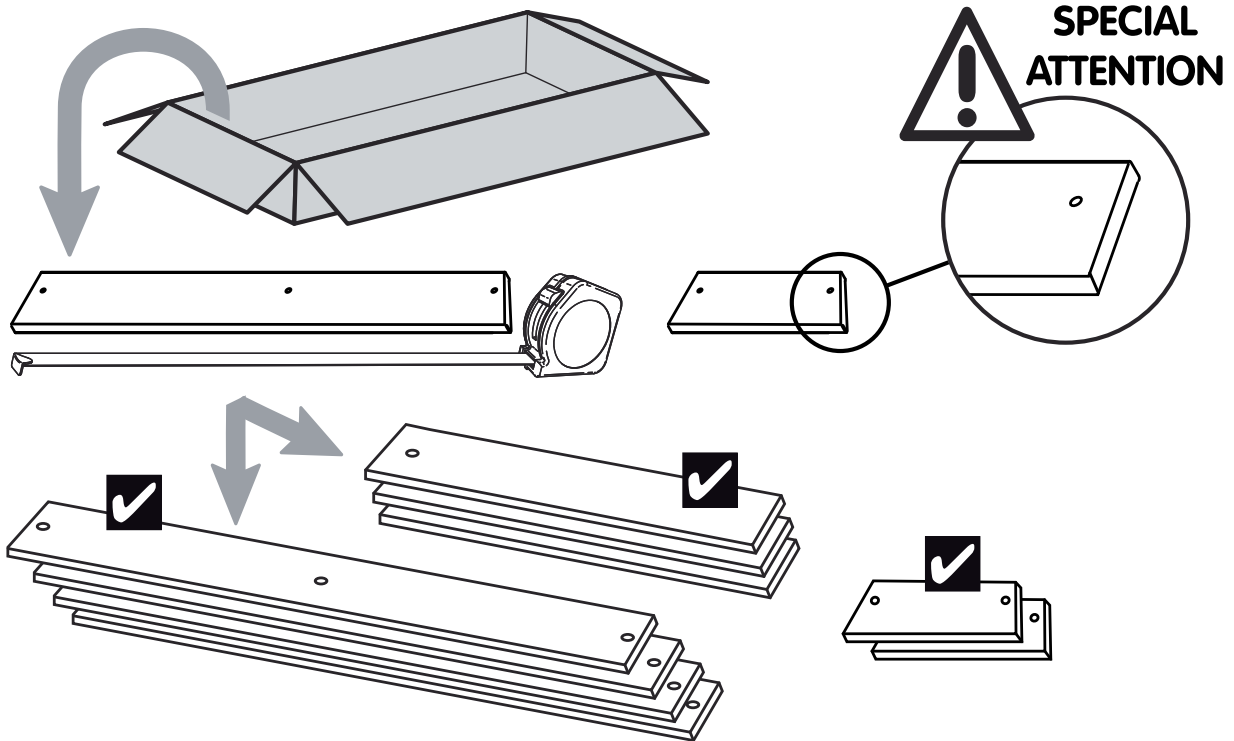

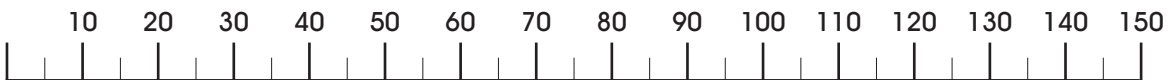

Sort Parts

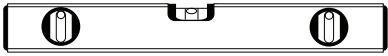
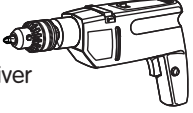

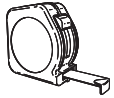
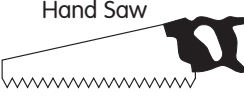
Need Help? Visit www.tptoys.com TP Customer Services: (English Speaking)

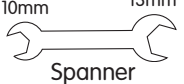
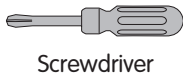

Contents - Please check		Tools - You will need:	
Siete Pregati di Controllare il Contenuto		Vous aurez besoin de:	
Verifique El Contenido	Conteúdos - Por favor verifique	Sie benötigen:	
Inhalt - Bitte Überprüfen	Contenu - Veuillez Vérifier	Avrete bisogno:	
Contenu - Veuillez Vérifier		Vai precisar:	
 Spirit Level	 Power Screwdriver	 3mm Drill Bit	 Step Ladder
 Tape Measure	 Hand Saw	 Pozi #2 Pozi #3	 Spanner 10mm 13mm
		 Screwdriver	 Socket 13mm Wrench

Pack 1

MW2018 **x1** (2237mm)



MW2019 **x2** (2237mm)

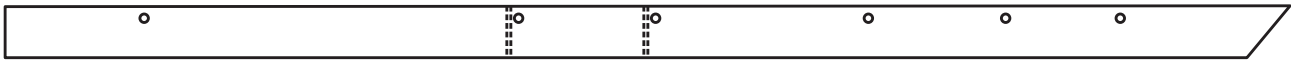

MW2020 **x1** (2237mm)



MW2021 **x1** (2237mm)



MW2022 **x1** (2237mm)



Pack 2

MW2023 **x3** (650mm)

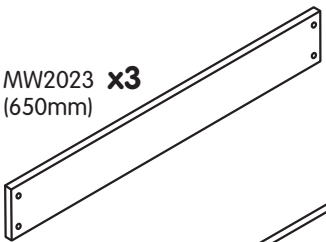

MW2026 **x4** (381mm)



MW2027 **x4** (724mm)



MW2029 **x5** (974mm)



MW2031 **x3** (1024mm)

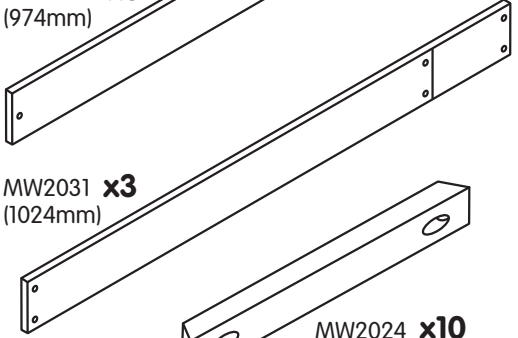

MW2024 **x10** (579mm)

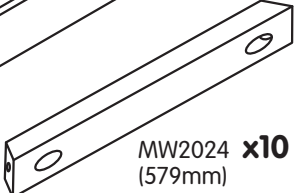

MW2025 **x1** (1104mm)

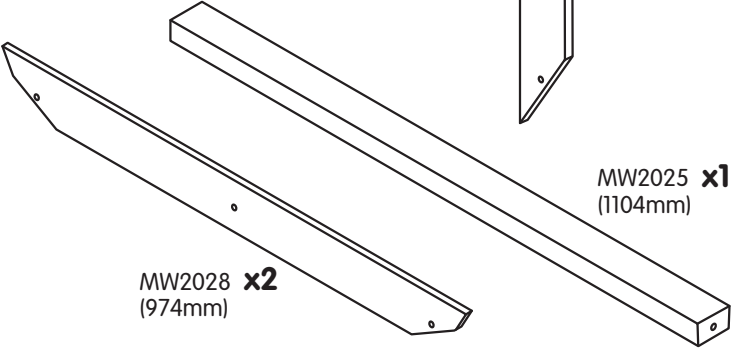

MW2028 **x2** (974mm)

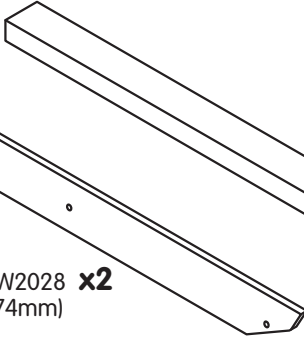

Pack 3

FB3041 x2
Sandpit Liner

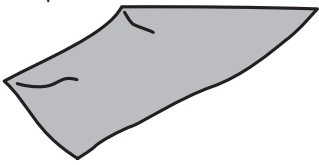

PR5069 x3



MW0176 x4
(413mm)

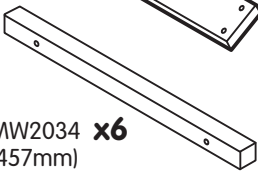

MW2050 x2
(589mm)

MW2051 x2
(589mm)

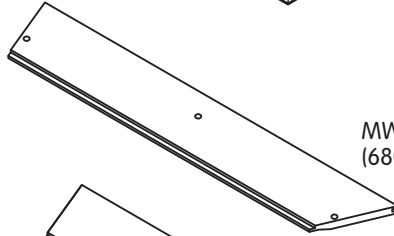

PM1005 x1



MW2034 x6
(457mm)

MW2035 x1
(586mm)

MW2041 x6
(680mm)

PM1007 x1



PM1006 x1



MW2036 x6
(589mm)

MW2042 x6
(585mm)

MW2040 x6
(915mm)

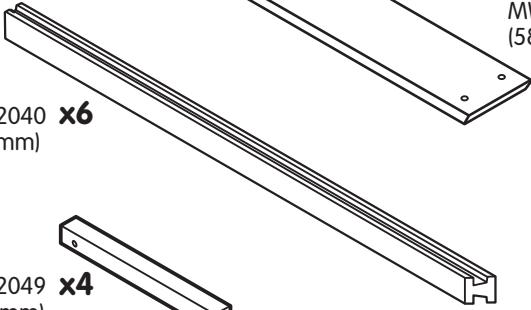

MW2043 x6
(490mm)

MW2049 x4
(300mm)



MW2044 x6
(395mm)

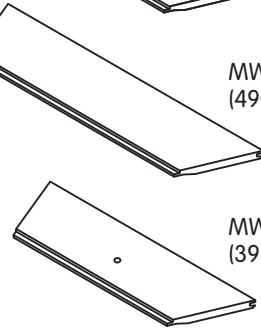

MW2037 x20
(118mm)



MW2038 x1
(579mm)



MW2045 x6
(301mm)

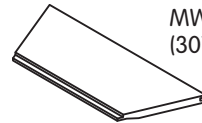

MW2052 x2

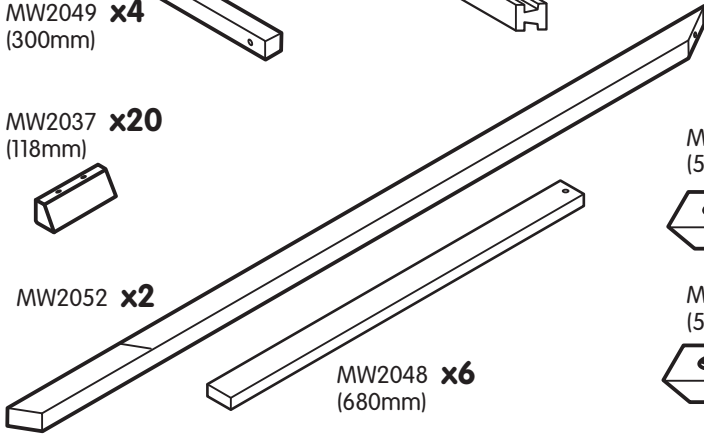

MW2048 x6
(680mm)

MW2039 x1
(579mm)

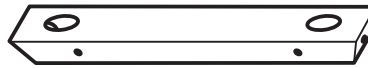

MW2046 x6
(206mm)



MW2047 x6
(111mm)



MW2057 x12

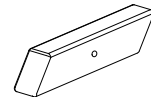

MT0606 x1

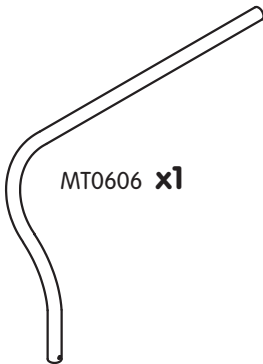

MT9471
Fireman's Pole (Bottom) **x1**

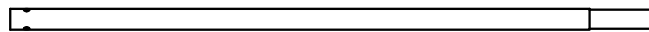

MT9127
Fireman's Pole Bottom Bar **x1**



MT9126
Fireman's Pole Cross Bar **x1**

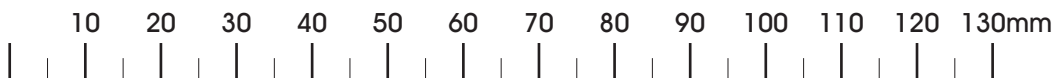

Fixings - SP 8500

FA4513
4.5mm x 30mm Woodscrew **x45**



FA7184
M8 Washer
(25mm o/dia)
x33



FA9723
M5 Washer
x6



FA4508
M5 Dome
Lock Nut
x6



FA9023
M6 Dome
Lock Nut
x1



FA4515
4.5mm x 55mm Woodscrew **x74**

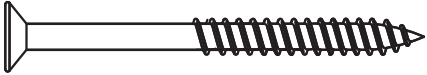

FA5094
M6 Washer
x1



FA8163
M8 Dome
Lock Nut
x16



PM8293
10mm Plug
x2

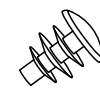

FA4502
4.5mm x 80mm Woodscrew **x7**

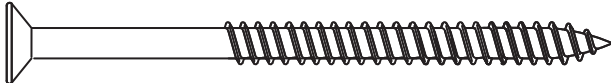

PM8294
12mm Plug
x20

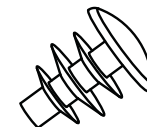

FA8442
5mm x 40mm Woodscrew **x117**

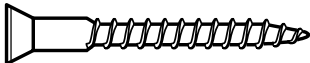

FA8380
M8 x 40mm Coach screw **x3**



FA8443
N°12 x 63mm (2½") **x2**

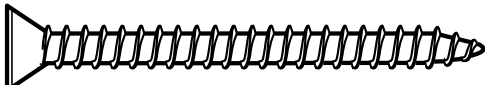

FA9784
M6 x 150mm Woodscrew **x2**

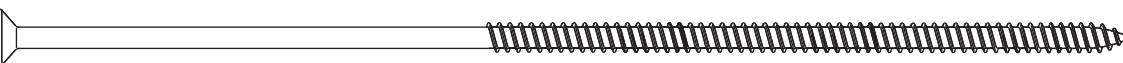

FA9724
M5 x 25mm Bolt **x6**

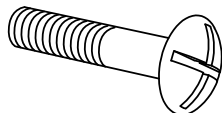

FA5170
M6 x 70mm Bolt **x1**

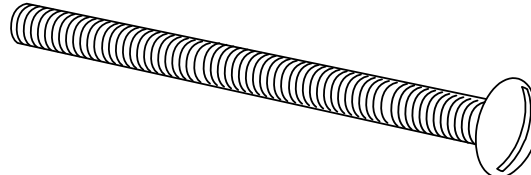

FA5688
M8 x 70mm Bolt **x8**

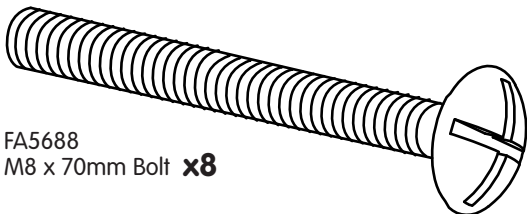

FA9701
M8 x 100mm Bolt **x8**

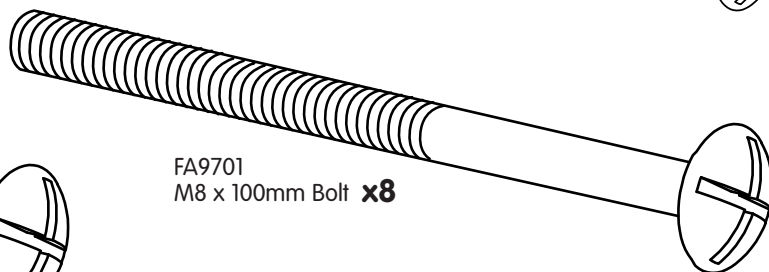

1

FA4515
4.5mm x 55mm
Woodscrew **x24**

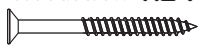

MW2037 **x12**



MW2018 **x1** (2237mm)



MW2019 **x2** (2237mm)



MW2020 **x1** (2237mm)

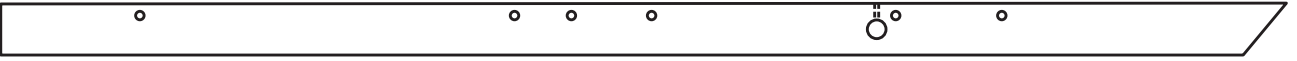

MW2021 **x1** (2237mm)

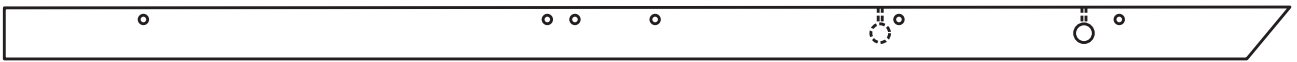

MW2022 **x1** (2237mm)

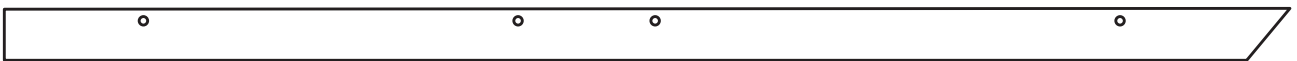

x6

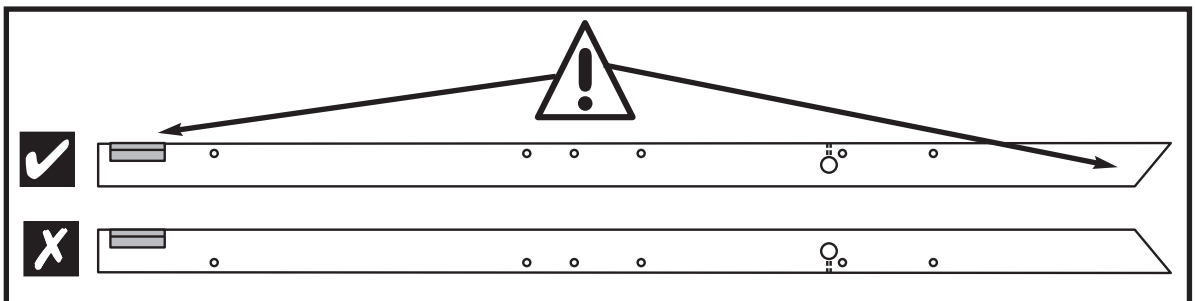
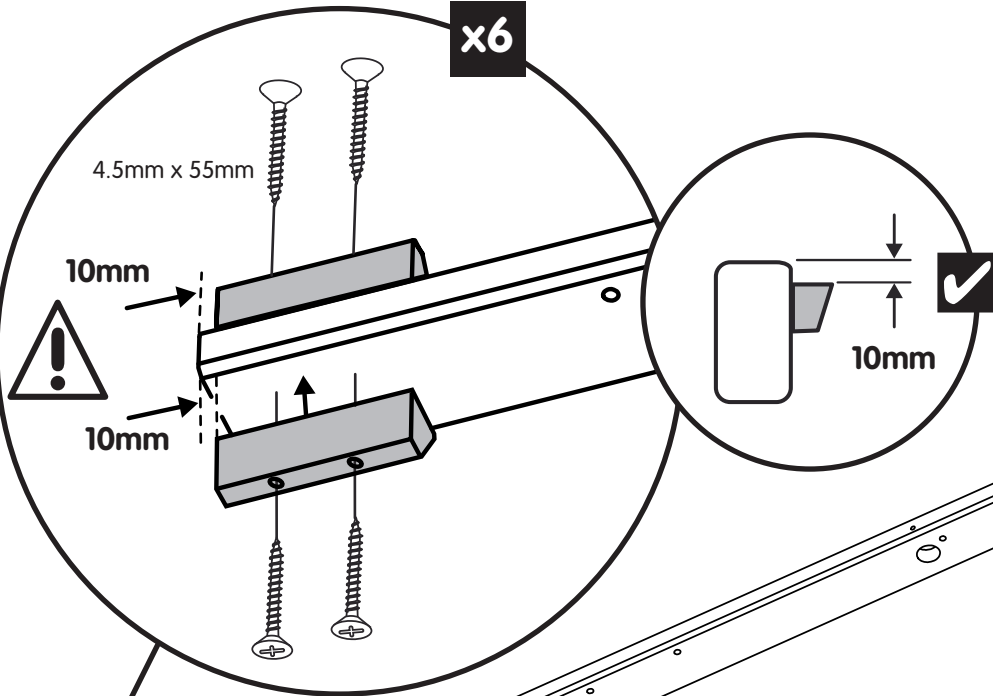

2



MW2024 x3 (589mm)

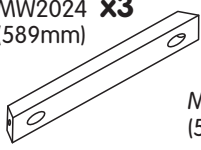

MW2036 x1 (589mm)

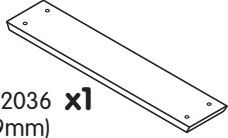

FA7184 M8 Washer (25mm o/dia) x8



FA5688 M8 x 70mm Bolt x3



FA9701 M8 x 100mm Bolt x1

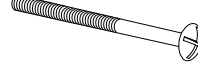

FA8163 M8 Dome Lock Nut x4



FA8442 5mm x 40mm Woodscrew x4

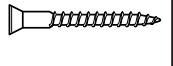

MW2019 x1 (2237mm)

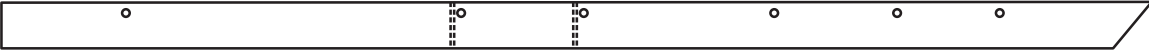

MW2020 x1 (2237mm)



MW2020

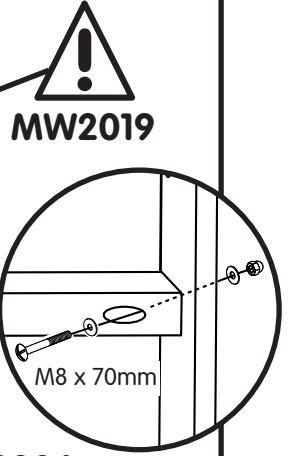
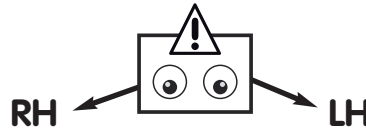

WARNING!

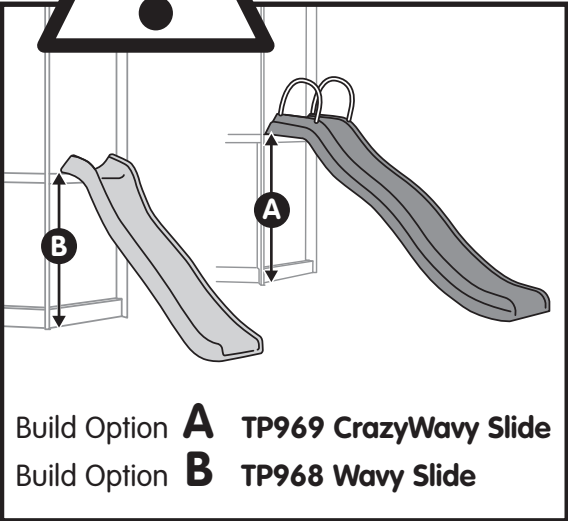

Build Option **A** TP969 CrazyWavy Slide
Build Option **B** TP968 Wavy Slide

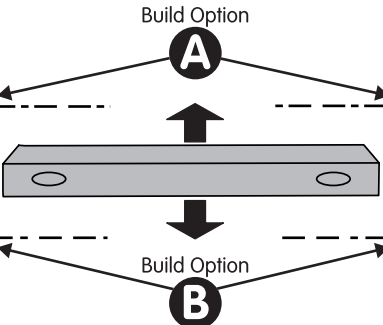

MW2024

MW2024

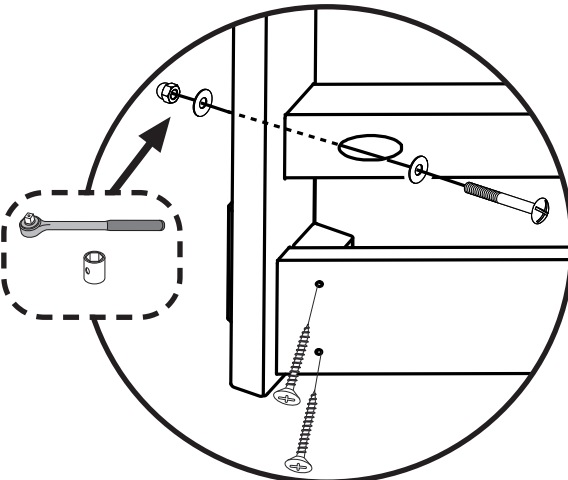
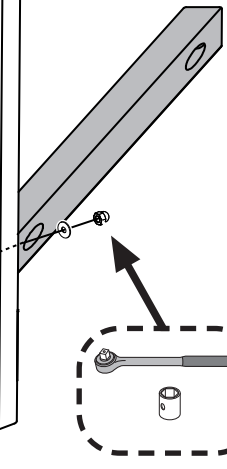

MW2024

M8 x 70mm — M8 x 100mm

MW2036

5mm x 40mm Woodscrew

3



MW2024 x2
(589mm)

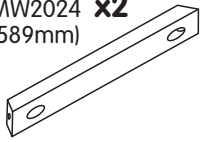

MW2039 x1
(579mm)

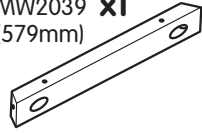

FA7184
M8 Washer
(25mm o/dia)
x4



FA9701
M8 x 100mm
Bolt
x2

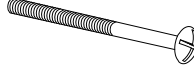

FA8163
M8 Dome
Lock Nut
x2



PM8293
10mm Plug
x2

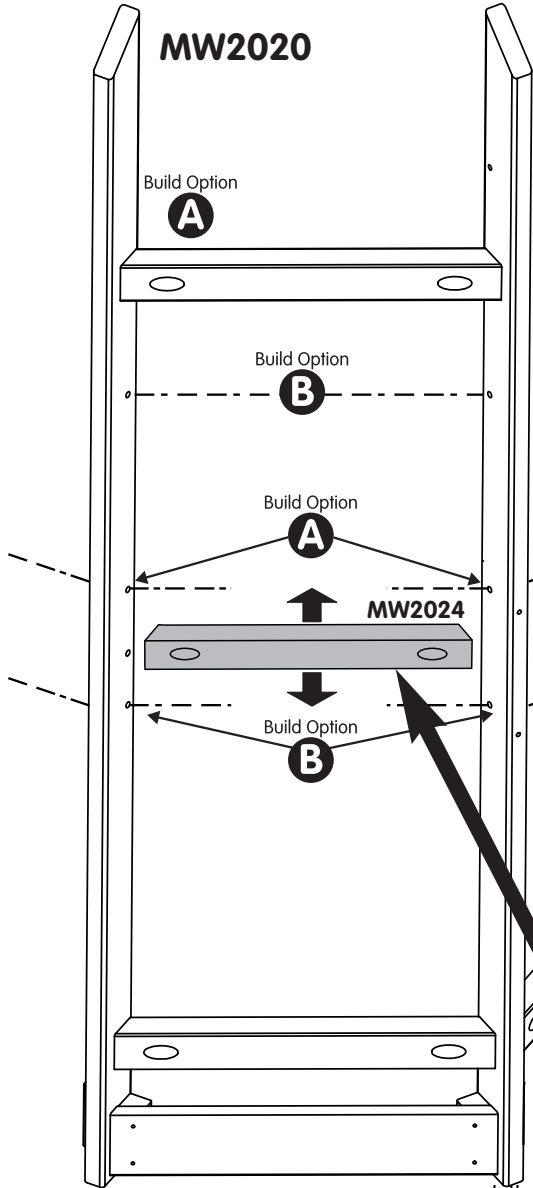

MW2019



WARNING!

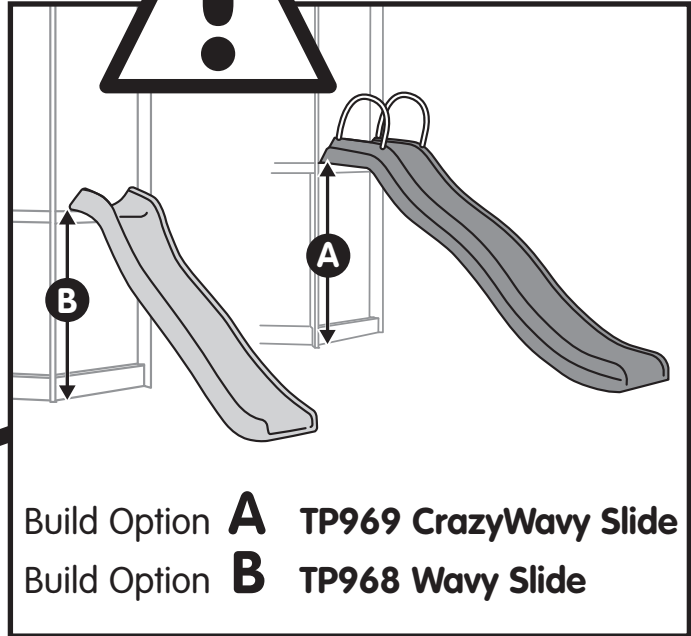

Build Option **A** TP969 CrazyWavy Slide
Build Option **B** TP968 Wavy Slide

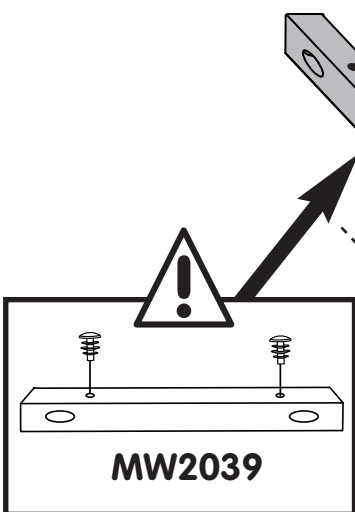

MW2039

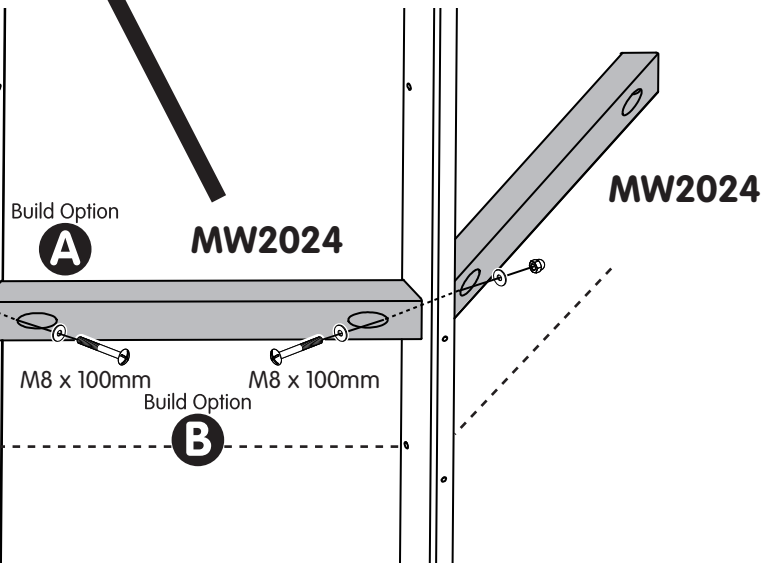

Build Option **A**

MW2024

M8 x 100mm

M8 x 100mm

Build Option **B**

MW2024

4



- MW2024 **x1** (589mm)
- MW2036 **x1** (589mm)
- MW2038 **x1**
- MW2022 **x1** (2237mm)
- FA7184 M8 Washer (25mm o/dia) **x8**
- FA5688 M8 x 70mm Bolt **x3**
- FA9701 M8 x 100mm Bolt **x1**
- FA8163 M8 Dome Lock Nut **x4**
- FA8442 5mm x 40mm Woodscrew **x4**

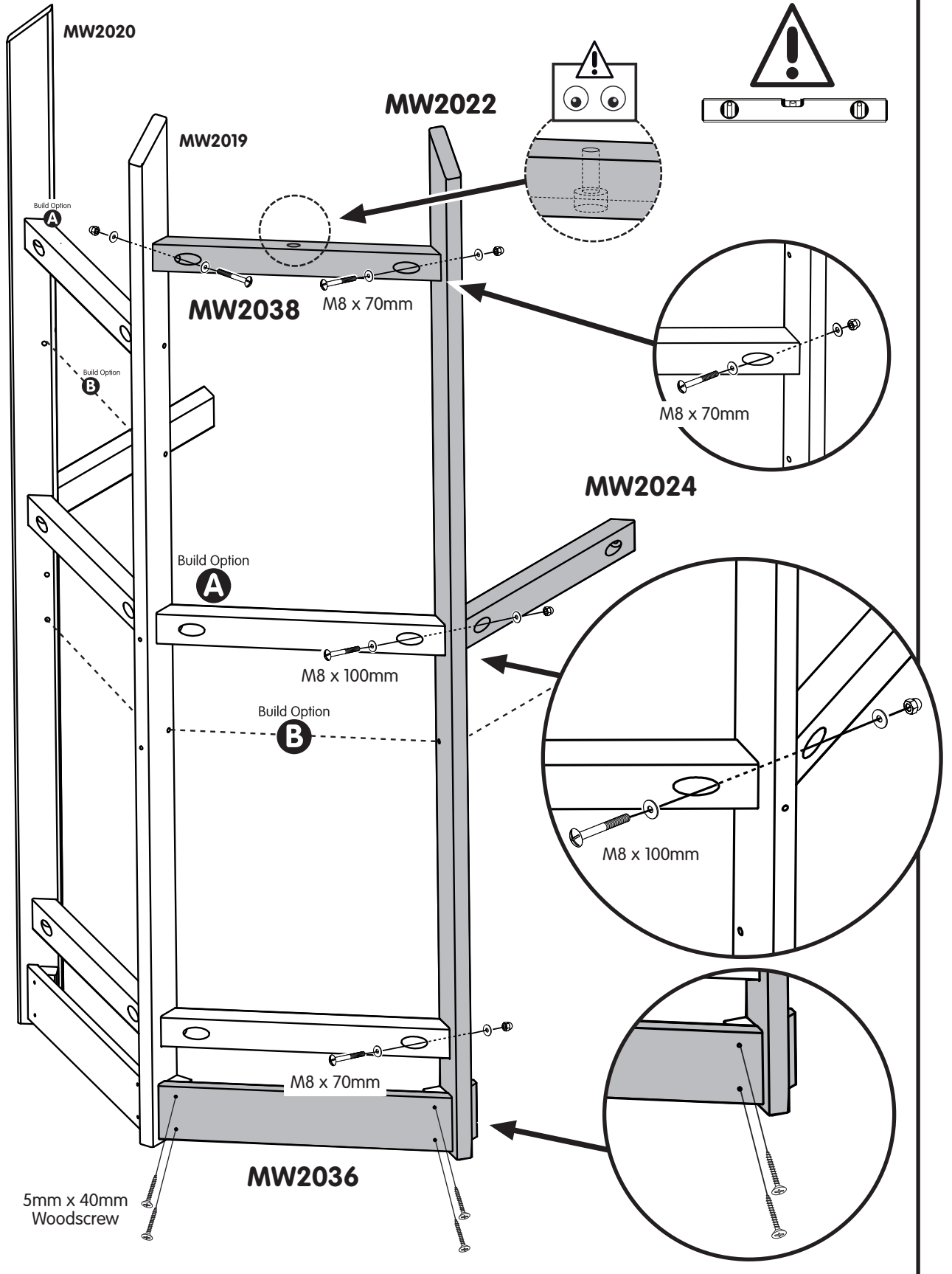

5



MW2024 x2 (589mm)

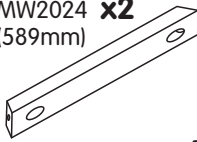

MW2036 x1 (589mm)

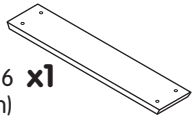

FA7184 M8 Washer (25mm o/dia) x4



FA5688 M8 x 70mm Bolt x1



FA9701 M8 x 100mm Bolt x1



FA8163 M8 Dome Lock Nut x2



FA8442 5mm x 40mm Woodscrew x4

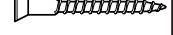

MW2018 x1 (2237mm)

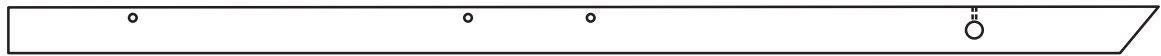

MW2019



MW2022

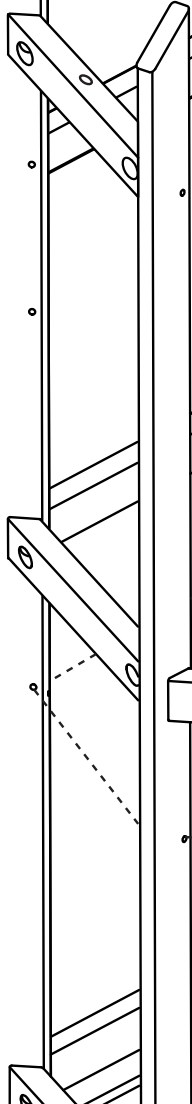

MW2020

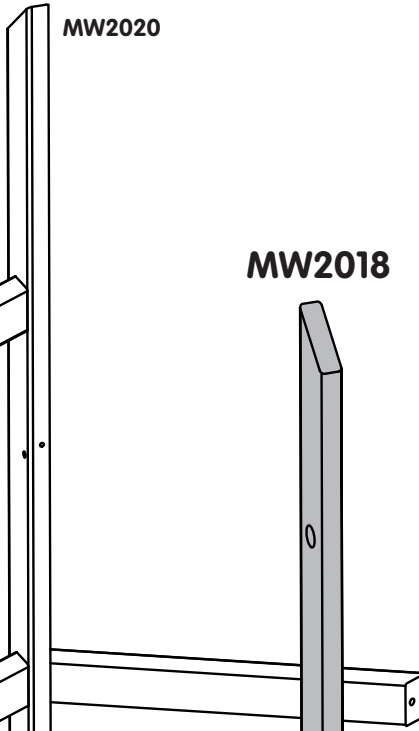

MW2018

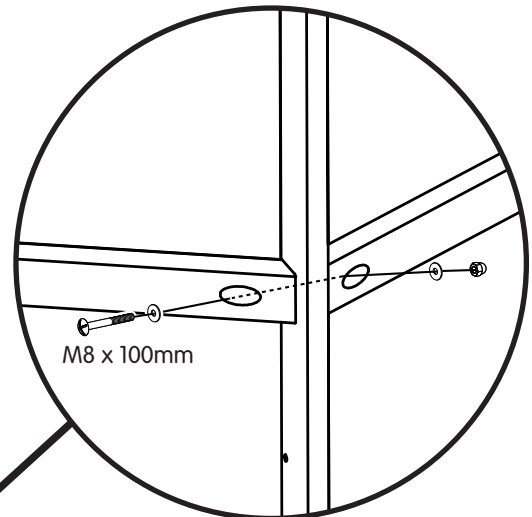
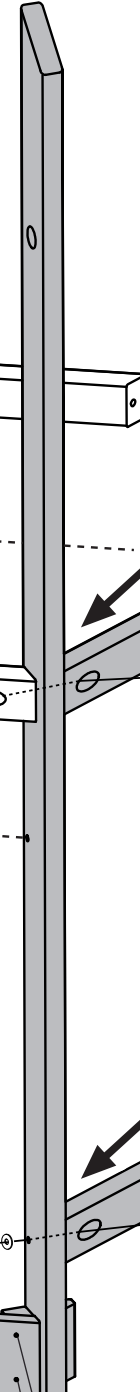

M8 x 100mm

Build Option

A

MW2024

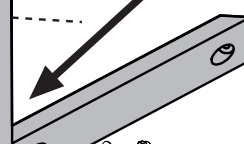

M8 x 100mm

Build Option

B

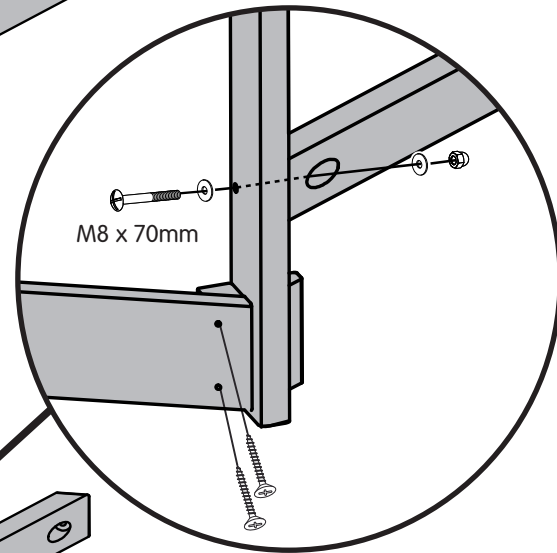

M8 x 70mm

MW2024

M8 x 70mm

5mm x 40mm Woodscrew

MW2036

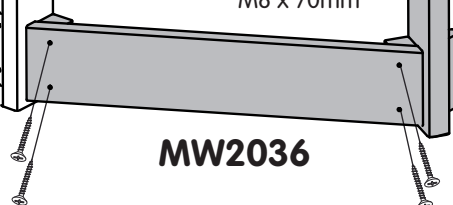

6



MW2024 **x2**
(589mm)

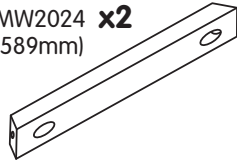

FA7184
M8 Washer
(25mm o/dia)
x4



FA9701
M8 x 100mm
Bolt
x2



FA8163
M8 Dome
Lock Nut
x2



MW2019 **x1** (2237mm)

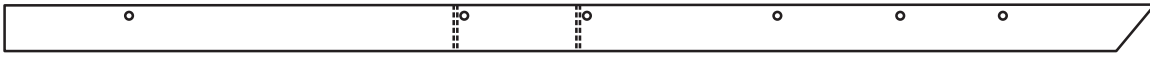

MW2018



MW2022

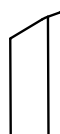

MW2019



MW2020

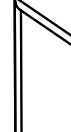

MW2019



MW2024



M8 x 100mm

MW2024



M8 x 100mm

7



MW2036 **x2**
(589mm)

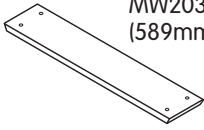

FA7184
M8 Washer
(25mm o/dia)
x4



FA5688
M8 x 70mm
Bolt
x1



FA9701
M8 x 100mm
Bolt
x1



FA8163
M8 Dome
Lock Nut
x2



FA8442
5mm x 40mm
Woodscrew
x8

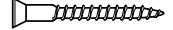

MW2021 **x1** (2237mm)

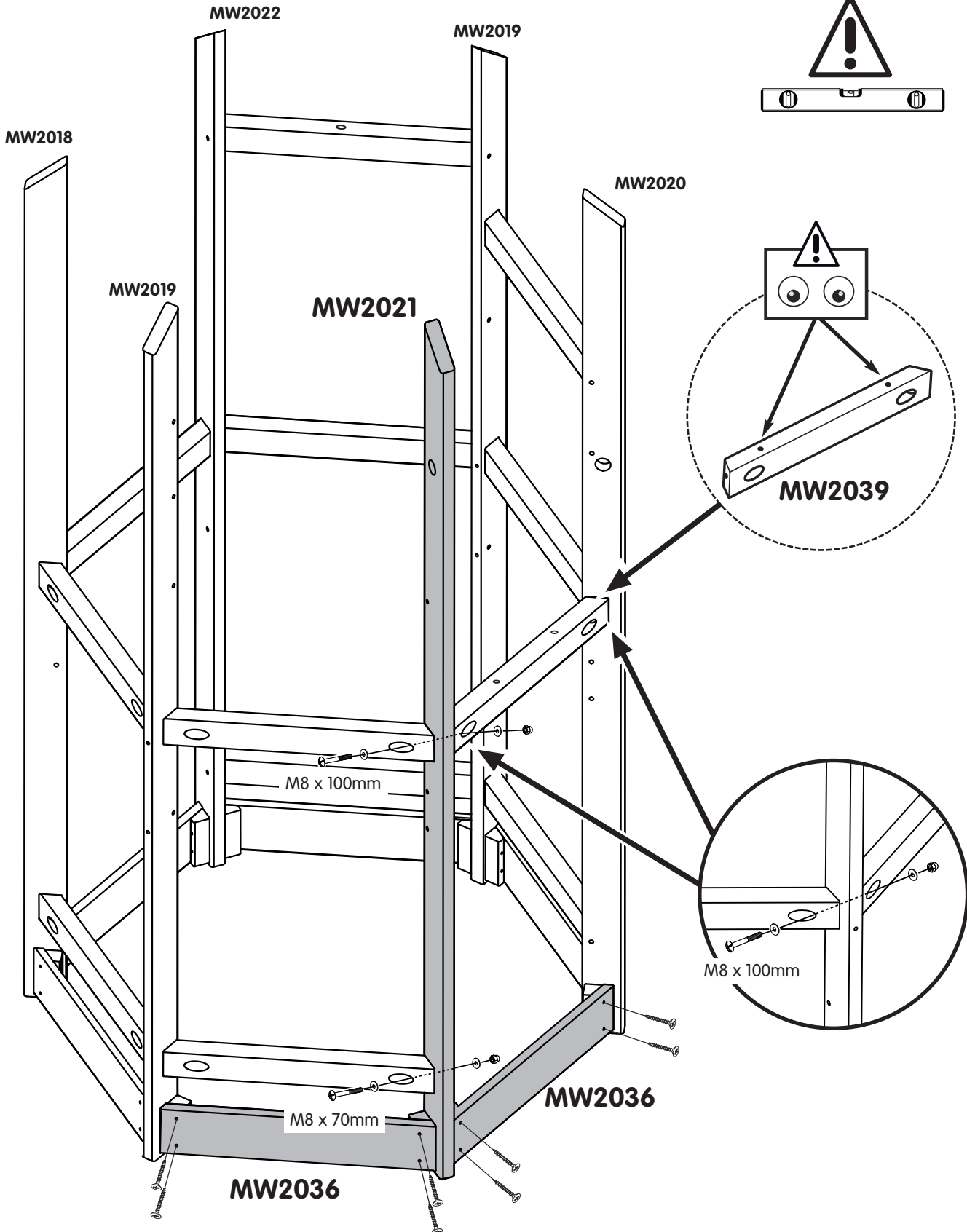
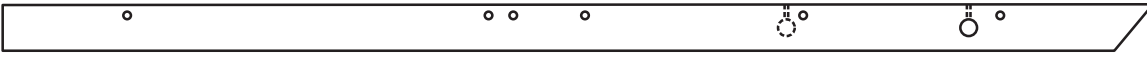

8

MW2034 **x6**
(457mm)

FA4515
4.5mm x 55mm
Woodscrew **x12**

15mm

15mm

15mm

ASSEMBLY TIP

MW2026
as guide

9

FA9784
M6 x 150mm Woodscrew **x2**

MW2025 **x1**
(1104mm)

Check

Build Option **A**

Build Option **B**

MW2019
Upright

10

MW2026 x2 (381mm) MW2027 x2 (724mm) MW2028 x2 (974mm) FA8442 5mm x 40mm Woodscrew x14

MW2019 Upright

Check

298mm

508mm

508mm

MW2019 Upright

508mm

508mm

11

MW2029 x5 (974mm) FA8442 5mm x 40mm Woodscrew x15

MW2019 Upright

Check

4mm

MW2019 Upright

12

MW2049 **x4**
(300mm)

FA4515
4.5mm x 55mm
Woodscrew **x8**

15mm

15mm

32mm

32mm

ASSEMBLY TIP

MW2026
as guide

13

FA8442
5mm x 40mm
Woodscrew **x8**

MW2026 **x2**
(381mm)

MW2027 **x2**
(724mm)

FA8442
5mm x 40mm
Woodscrew **x8**

MW2026 **x2**
(381mm)

MW2027 **x2**
(724mm)

14

Build Option A
TP969 CrazyWavy Slide

FA4515 4.5mm x 55mm
Woodscrew **x16**

MW2037 **x8**



Build Option B
TP968 Wavy Slide

FA4515 4.5mm x 55mm
Woodscrew **x12**

MW2037 **x6**





Check

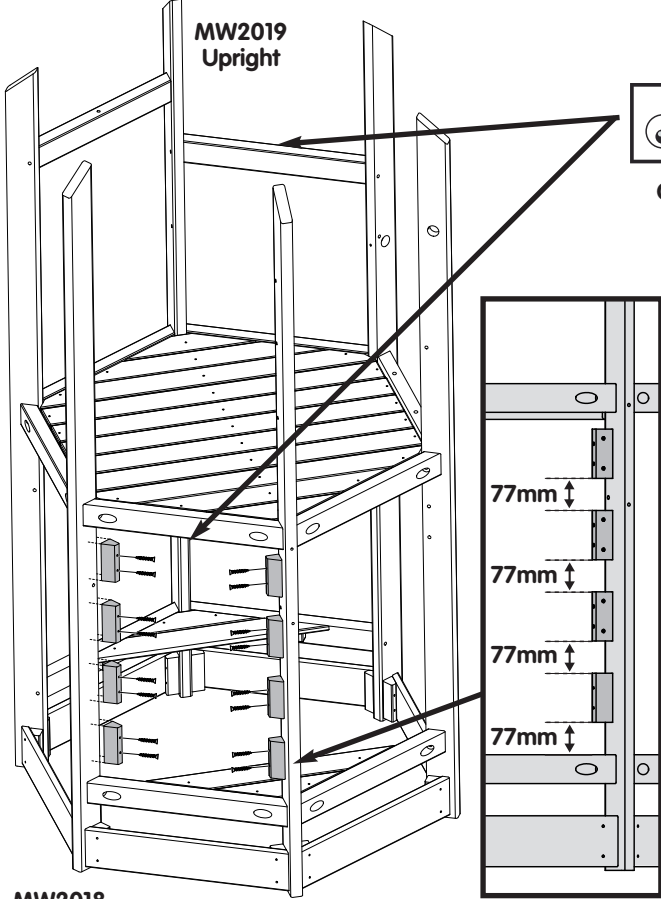

MW2019 Upright

MW2018 Upright

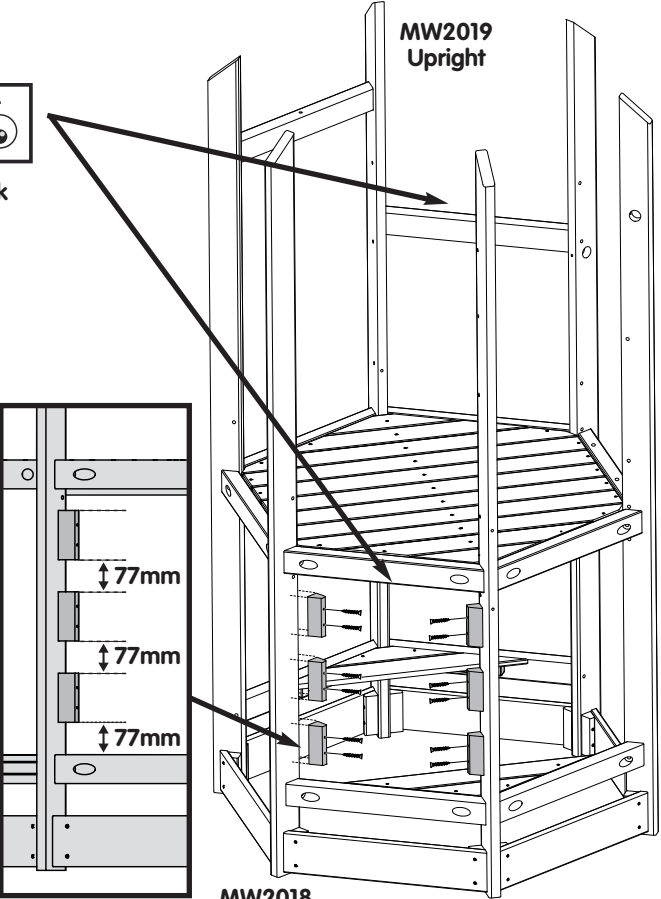

MW2019 Upright

MW2018 Upright

15

FA8442
5mm x 40mm
Woodscrew
x16

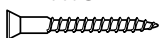

MW2051 **x2**
(589mm)

MW2050 **x2**
(589mm)

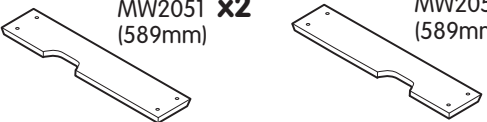

Build Option A
TP969 CrazyWavy Slide

x16

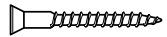

Build Option B
TP968 Wavy Slide

x12

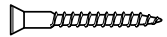

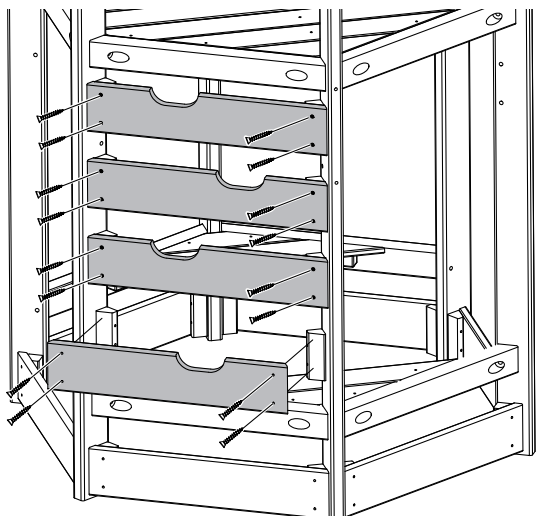

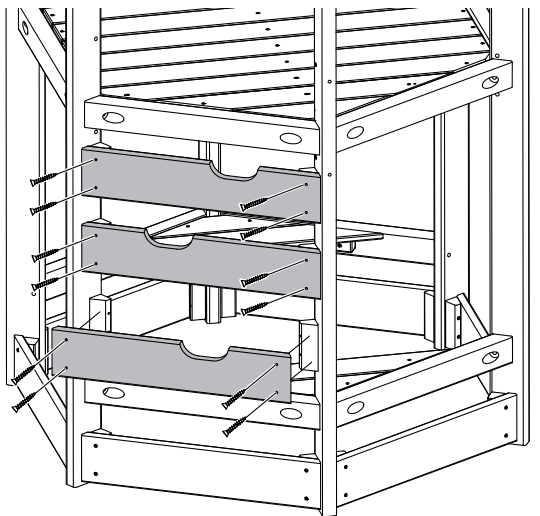

16

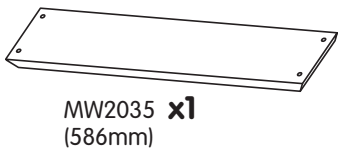
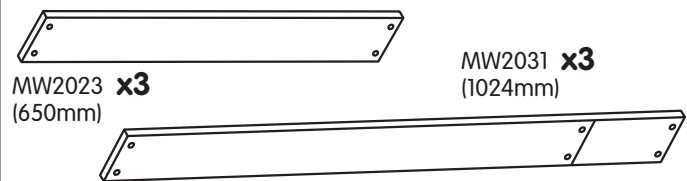

Build Option A TP969 CrazyWavy Slide



Check

MW2031 **x3**

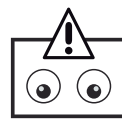
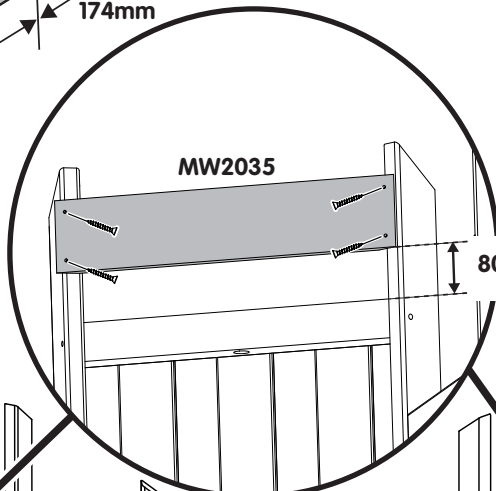
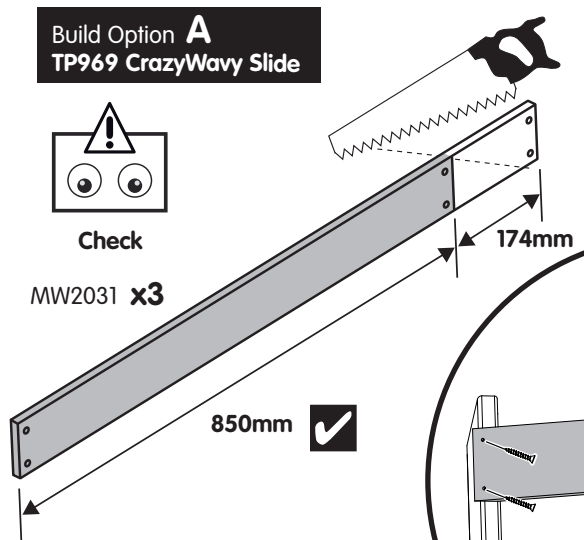

Check

Build Option B TP968 Wavy Slide

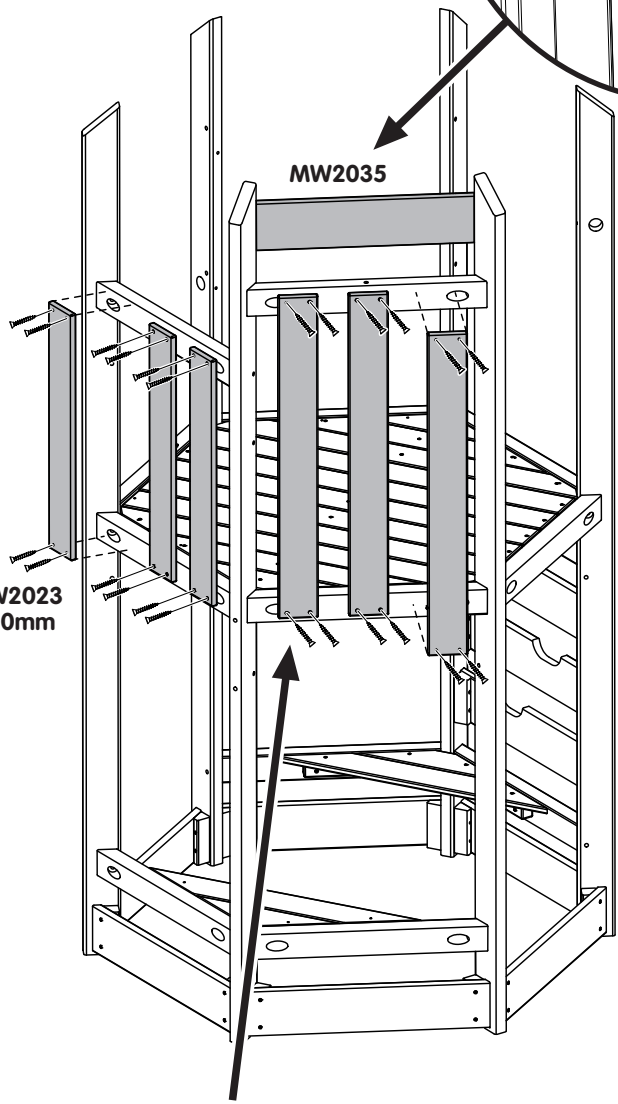

MW2031
850mm

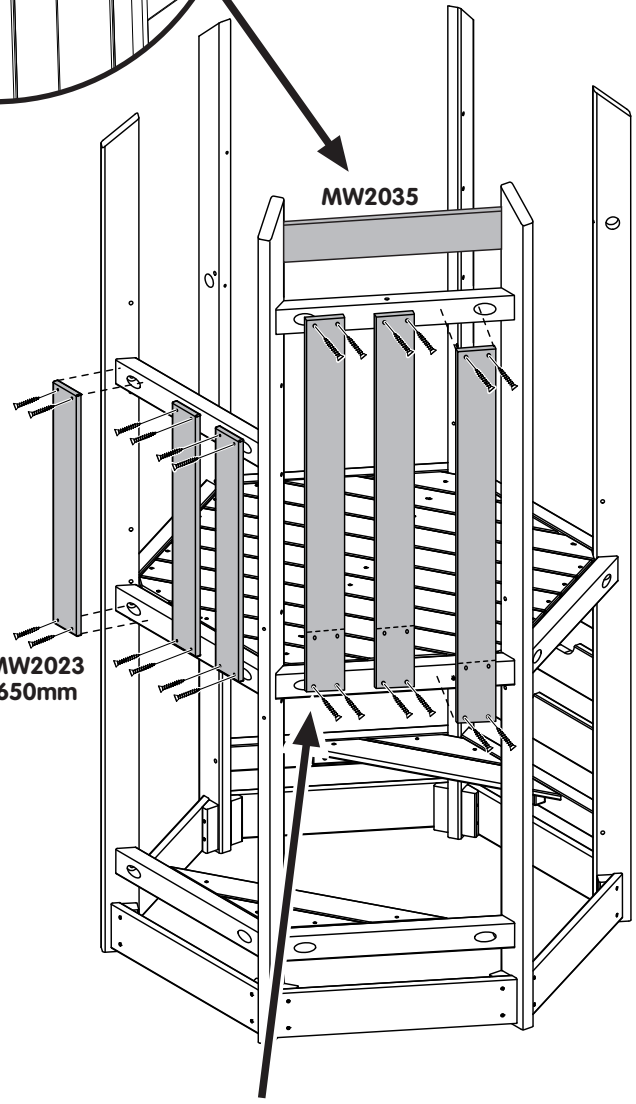

MW2031
1024mm

17

FA8442
5mm x 40mm
Woodscrew
x16

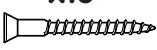

MW0176 **x4**
(413mm)

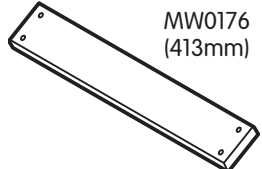

MW2052 **x2**



Build Option **A**
x16

TP969 CrazyWavy Slide



Build Option **B**
x12

TP968 Wavy Slide





Check

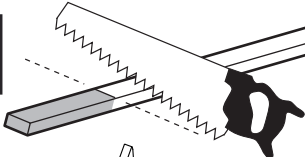

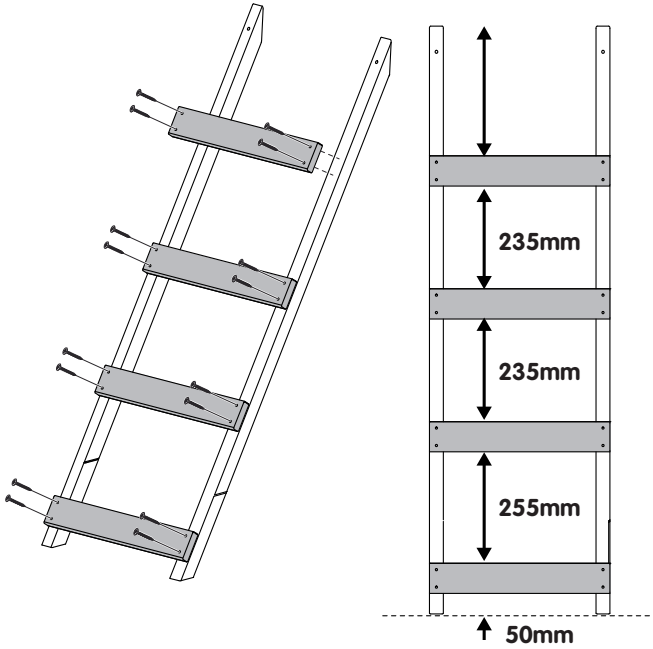

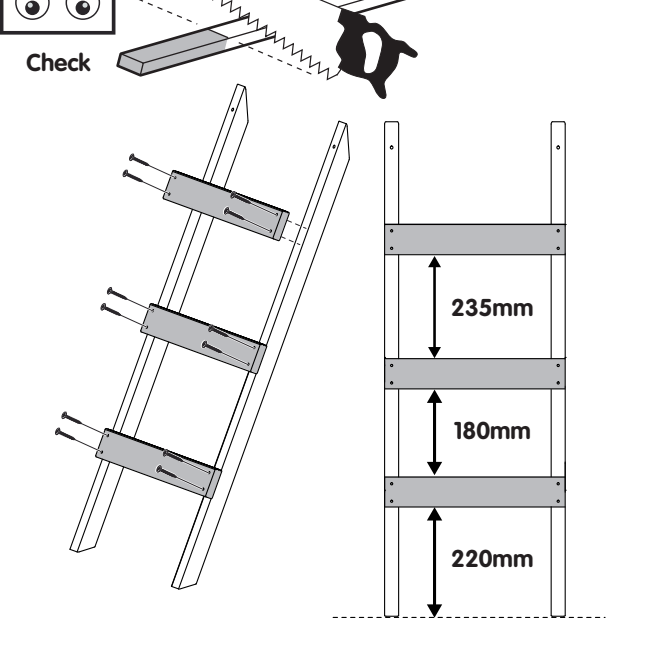

18

FA8443
N°12 x 63mm (2½") **x2**

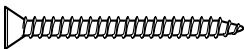

Build Option **A**

TP969 CrazyWavy Slide

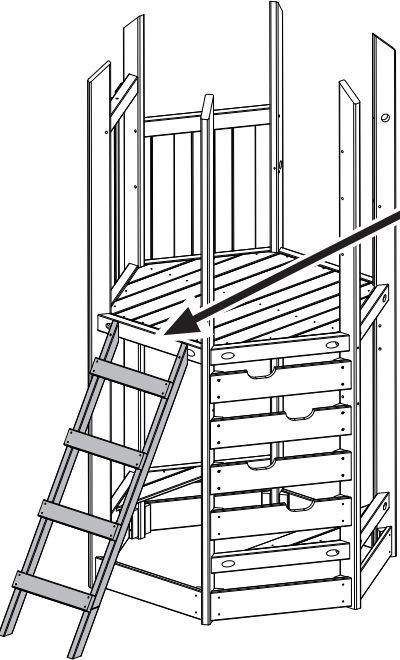





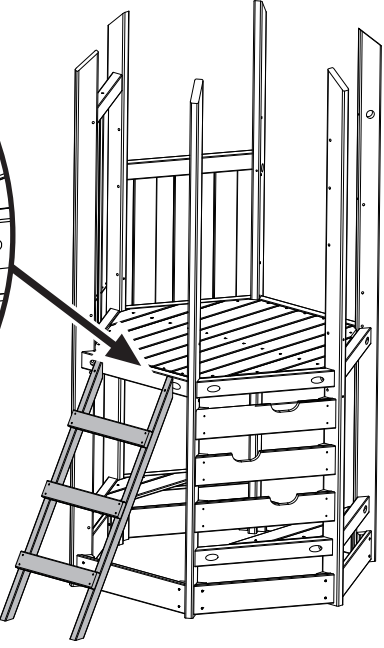

Build Option **B**

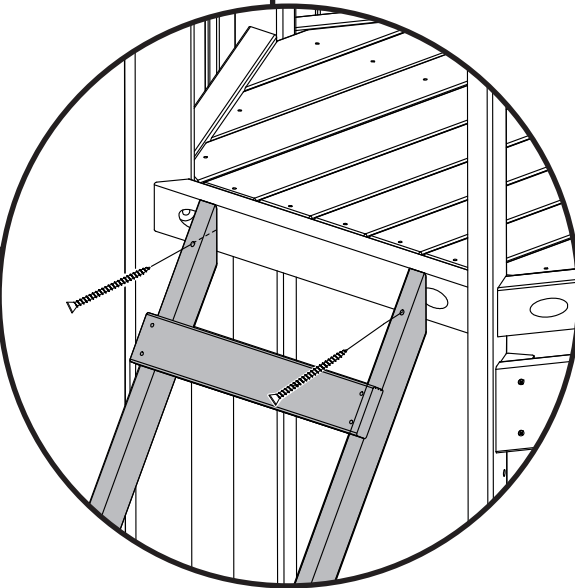
TP968 Wavy Slide



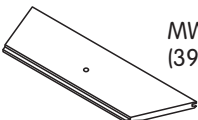
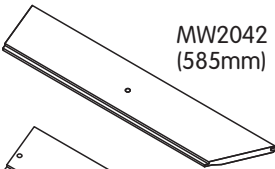

19

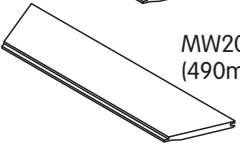
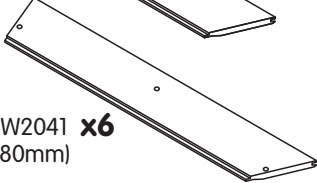
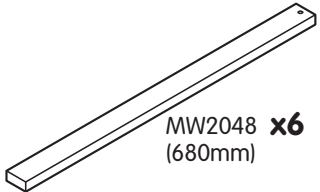
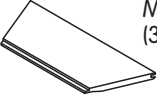
	MW2047 x6 (111mm)		MW2044 x6 (395mm)		MW2042 x6 (585mm)		FA4513 4.5mm x 30mm Woodscrew x24
	MW2046 x6 (206mm)		MW2043 x6 (490mm)		MW2041 x6 (680mm)		MW2048 x6 (680mm)
	MW2045 x6 (301mm)						

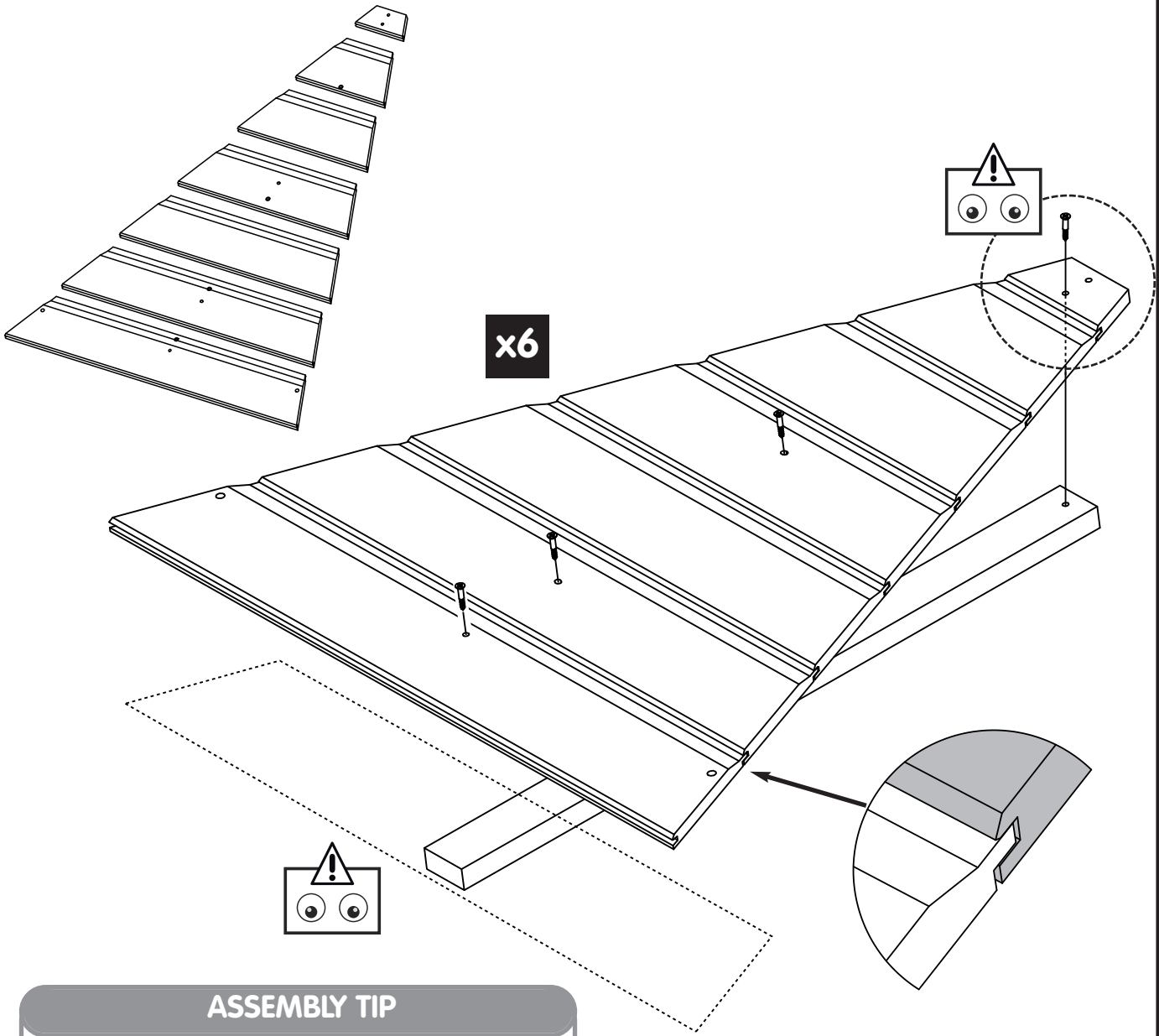

ASSEMBLY TIP

The assembly tip diagram shows two MW2048 parts being used to secure the structure. The parts are shown as L-shaped brackets that fit into the corners of the wooden frame. Dashed lines indicate the placement of the parts. The label 'MW2048' is placed next to each part.

20

PM1005 **x1**

FA4513
4.5mm x 30mm
Woodscrew **x6**

MW2040 **x6**
(915mm)

x6

21

PM1007 **x1**

CLICK

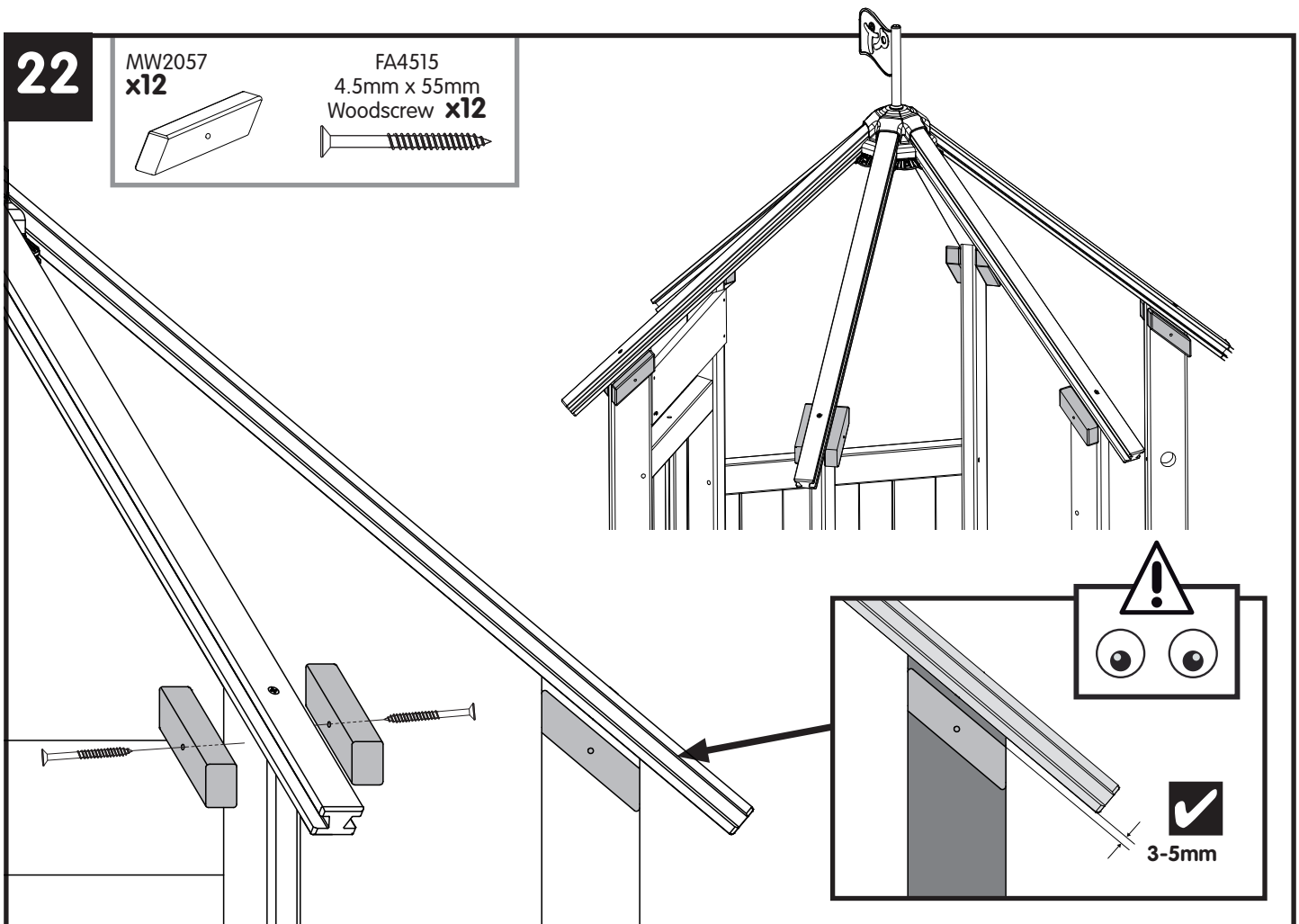
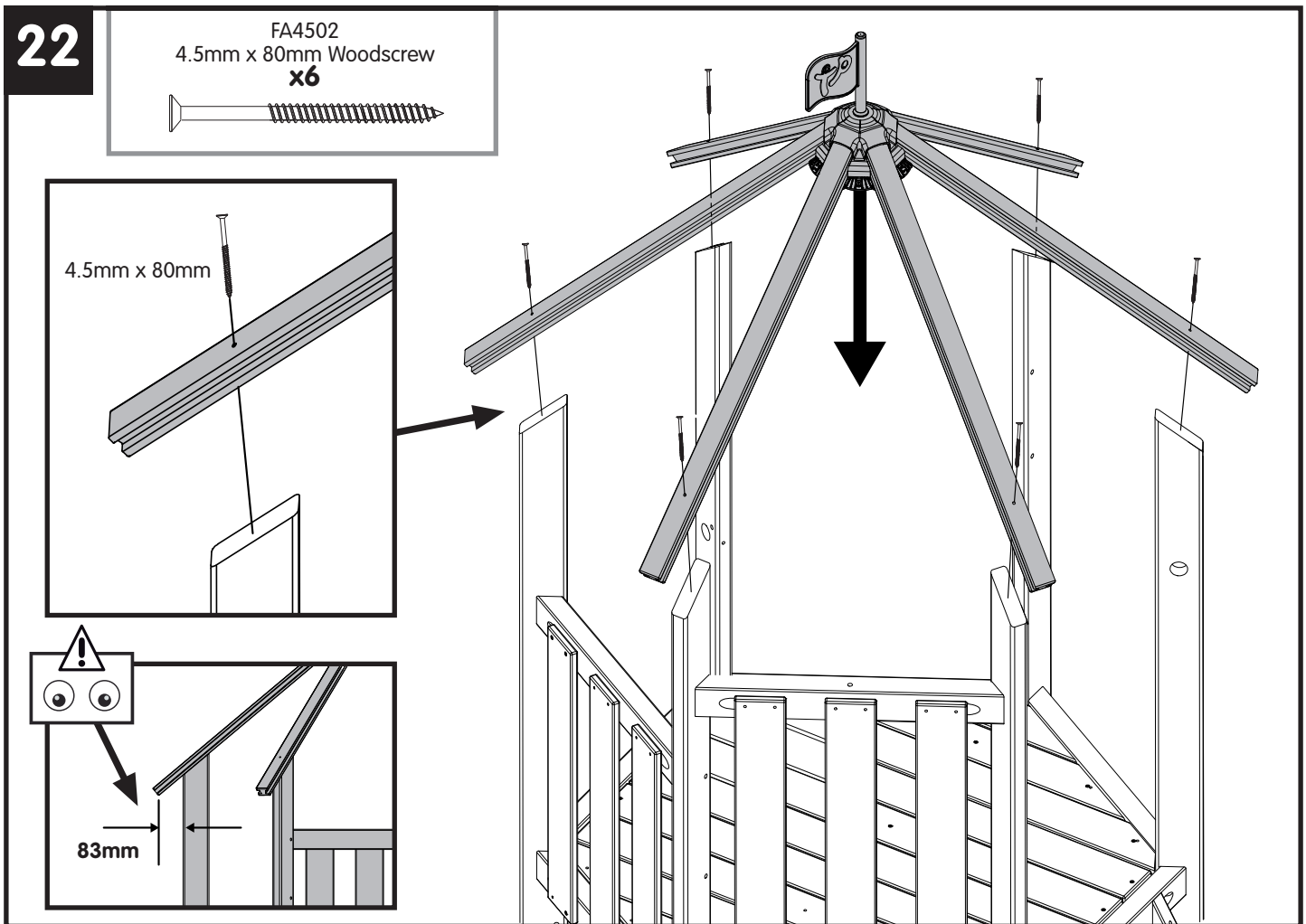

23

FA4508
M5 Dome Lock
Nut **6**



FA9724
M5 x 25mm Bolt
x6

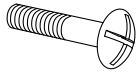

FA9723
M5 Washer
x6

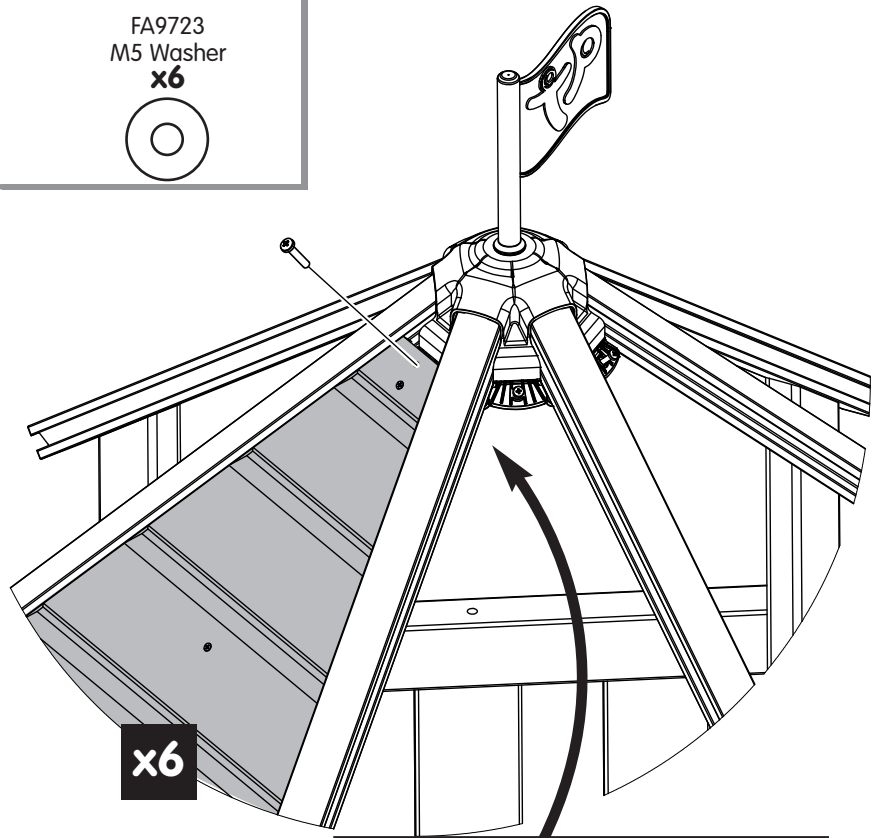
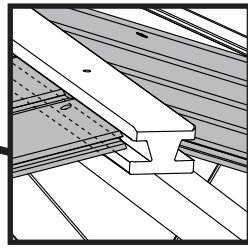
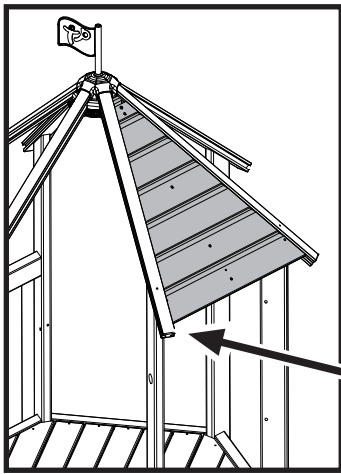
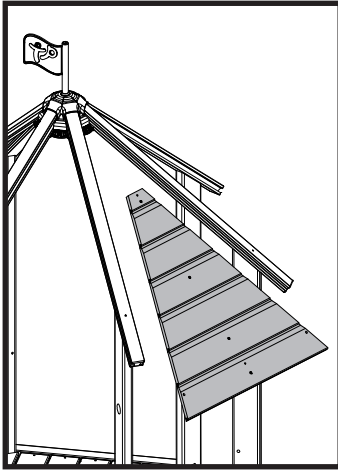

x6

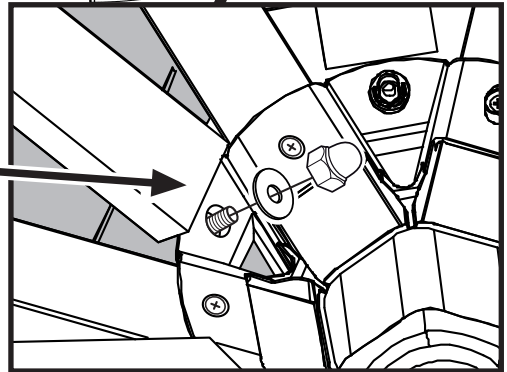

24

FA4513
4.5mm x 30mm
Woodscrew **x12**





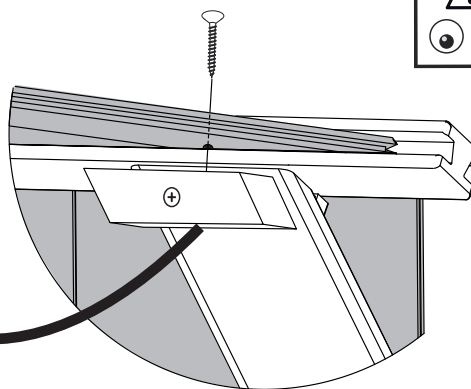
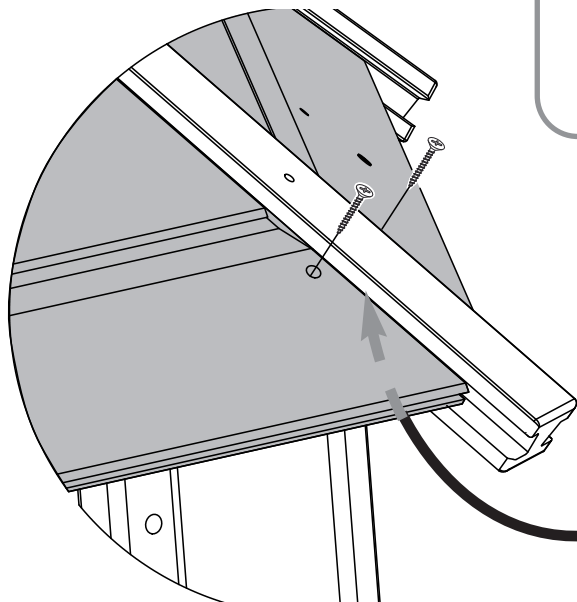
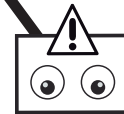
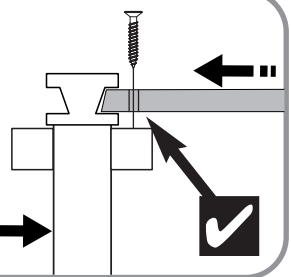
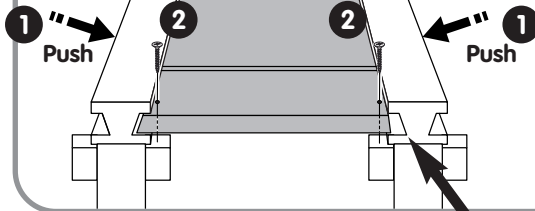



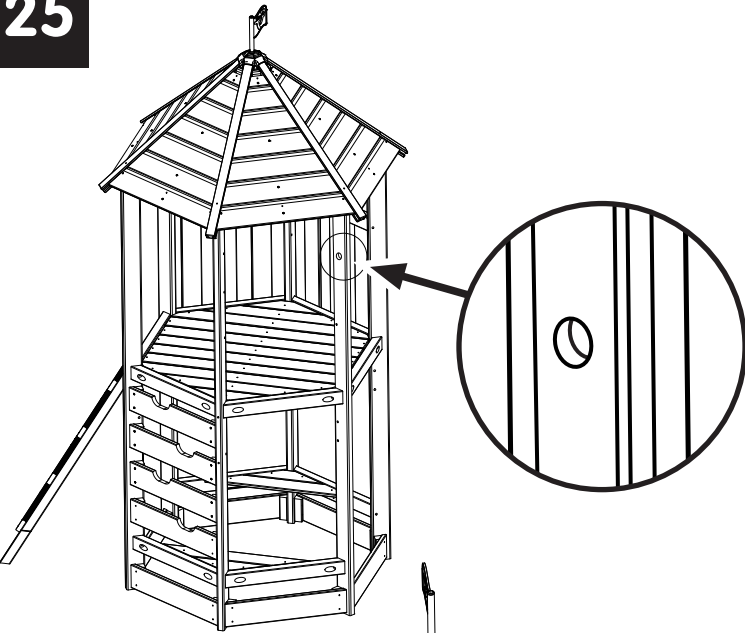

ASSEMBLY TIP

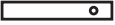

25

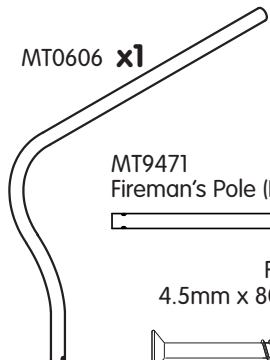
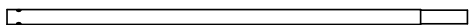

- FA5094 M6 Washer **x1** 
- PM1006 **x1** 
- FA4513 4.5mm x 30mm Woodscrew **x3** 
- FA5170 M6 x 70mm Bolt **x1** 
- FA9023 M6 Dome Lock Nut **x1** 
- MT9127 Fireman's Pole Bottom Bar **x1** 
- MT9126 Fireman's Pole Cross Bar **x1** 
- MT0606 **x1** 
- MT9471 Fireman's Pole (Bottom) **x1** 
- FA4502 4.5mm x 80mm Woodscrew **x1** 

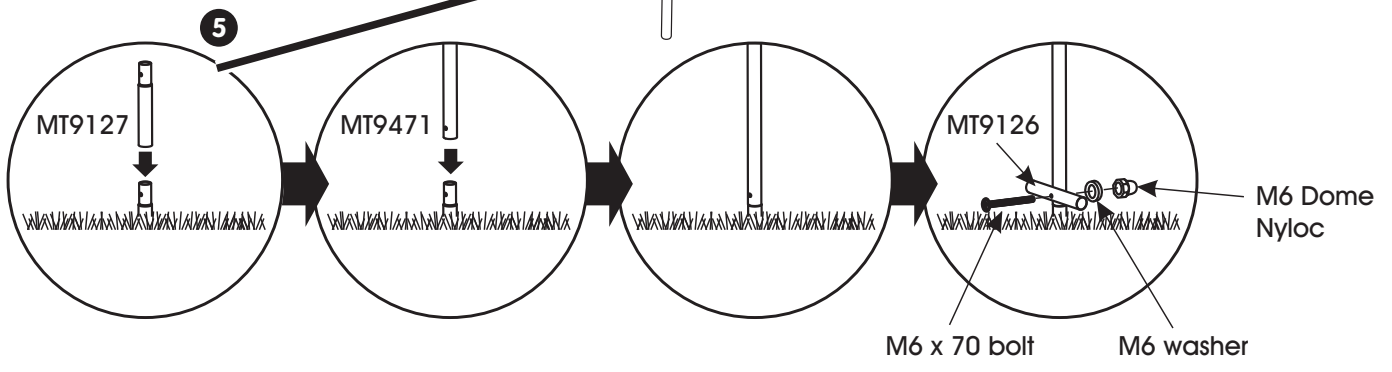
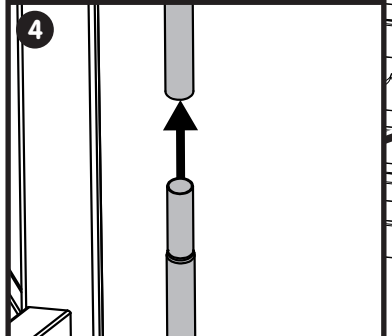
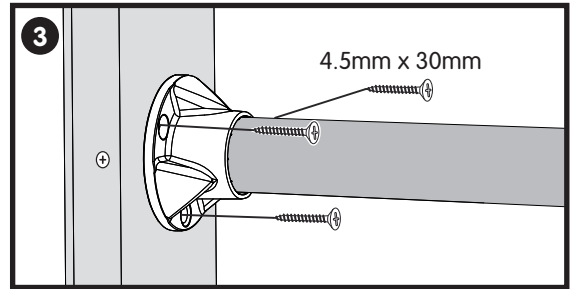
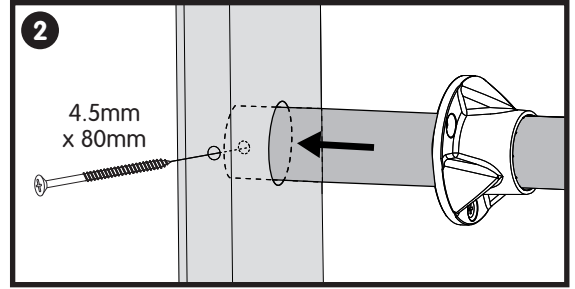
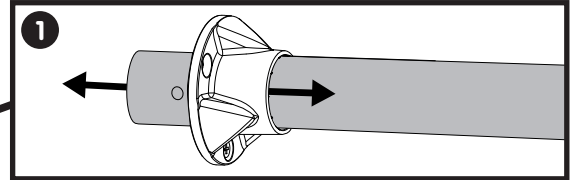
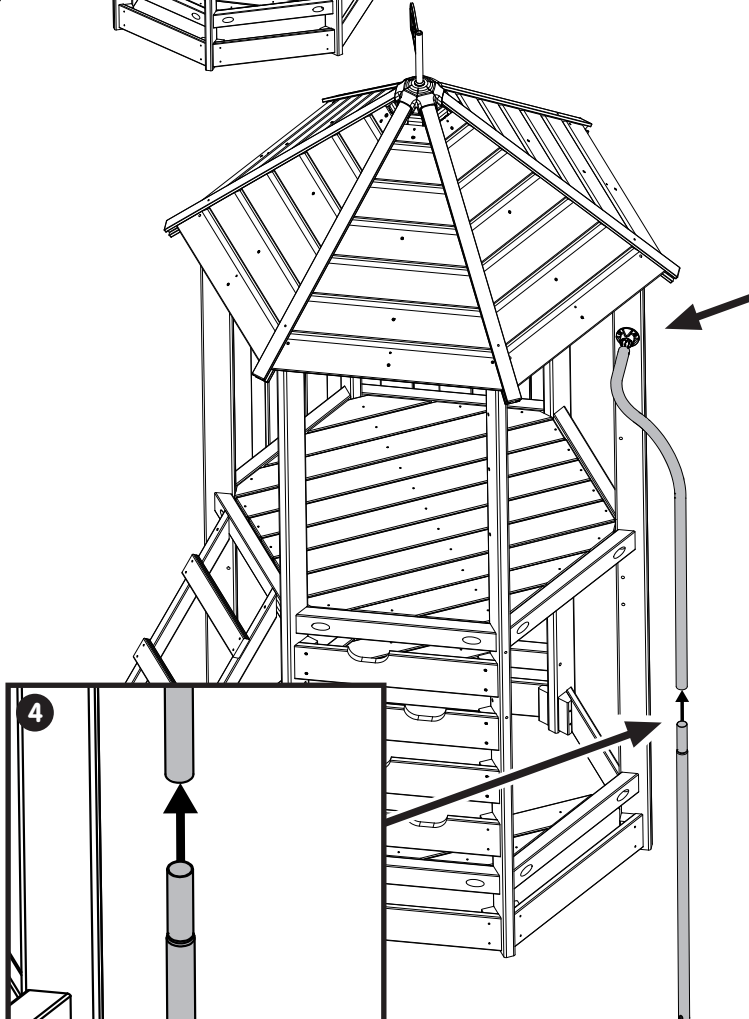

26

26

Slide Attachment

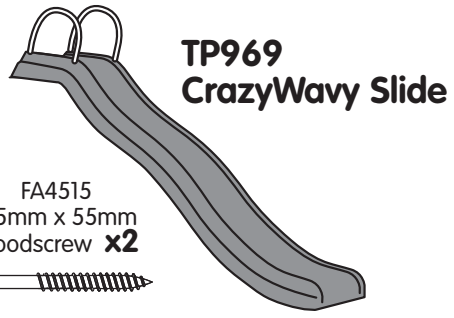

Build Option A
TP969 CrazyWavy Slide

Slide Attachment

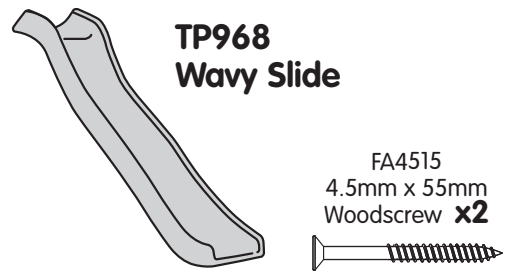

Build Option B
TP968 Wavy Slide

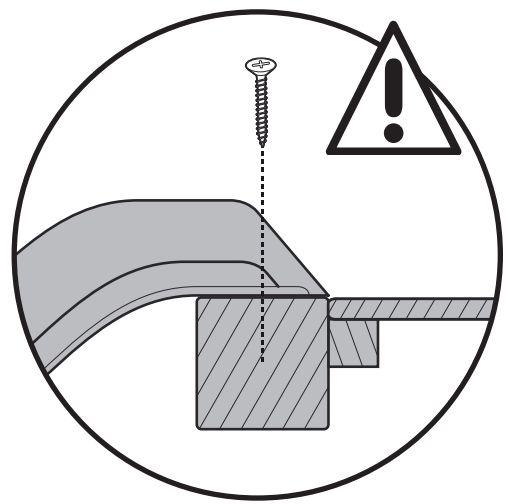
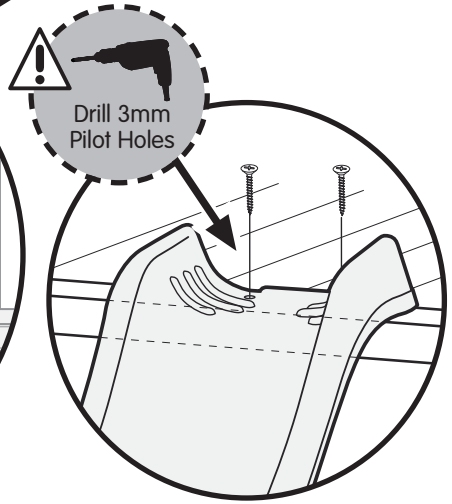
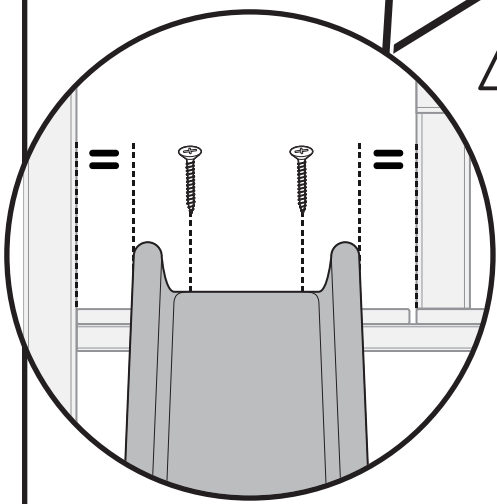
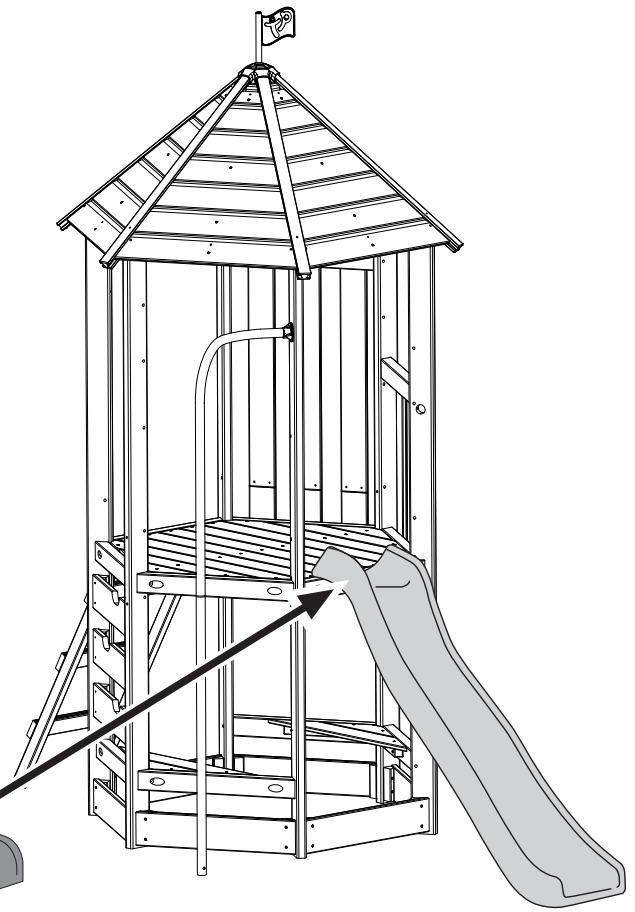
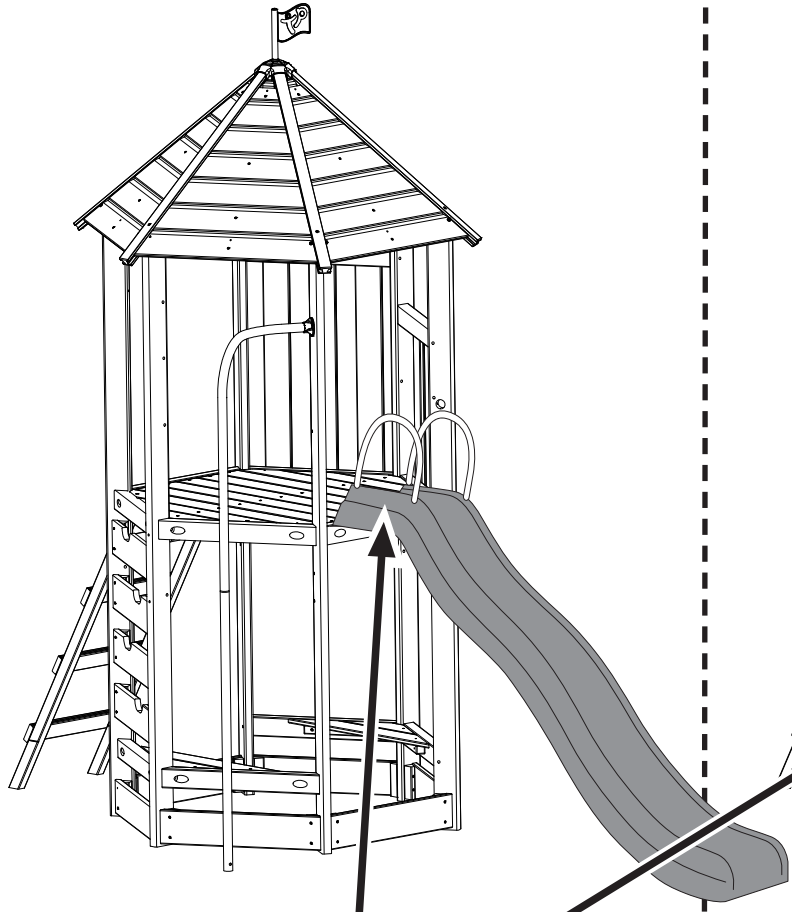

27

Positioning / Freespace / Safe Play Diagram

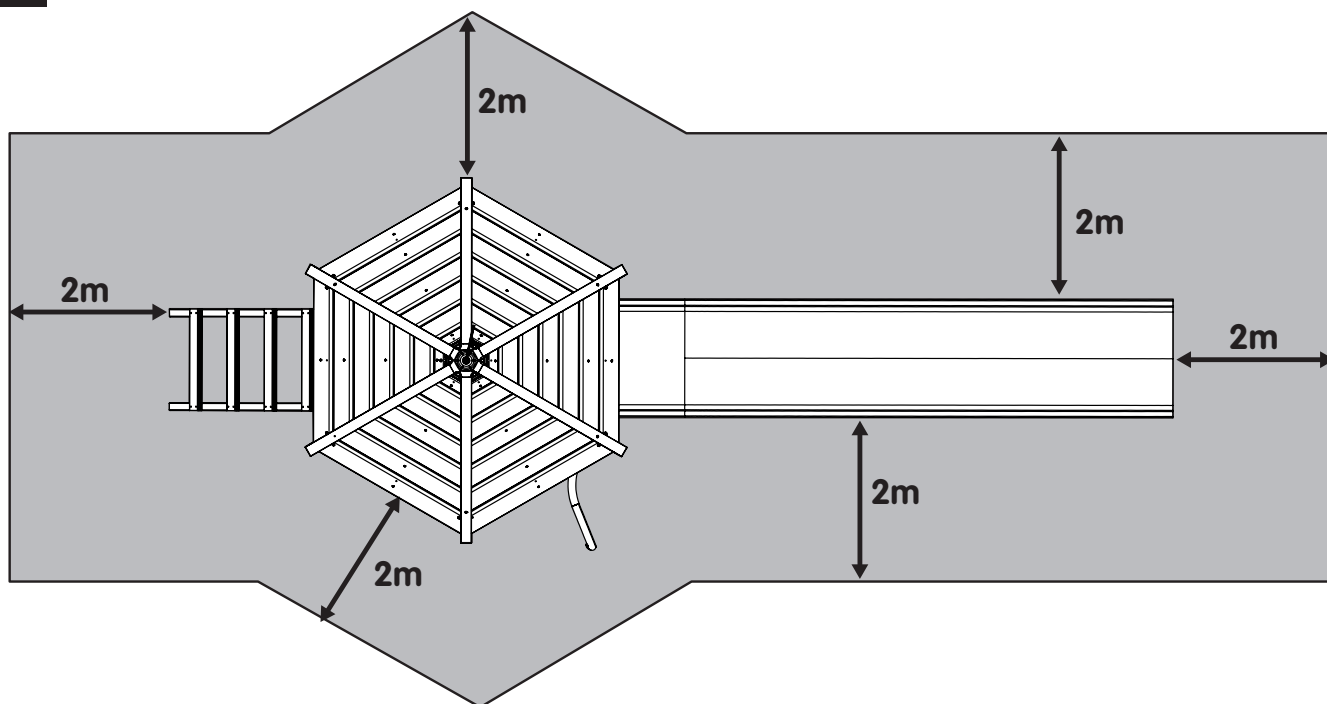
**Recommended Free Space:**

The Safe Play Area refers to the zone extending 200cm (2 metres) beyond the toy on all sides and 700cm (7 metres) above the toy. The Safe Play Area must be free from all structures, landscaping, trees and branches, rocks, wires, sprinkler heads and other similar obstacles to safe play. Children can be seriously injured running or colliding into such obstacles.

Aire de sécurité recommandée:

L'aire de sécurité se réfère à la zone située dans un rayon de 2 m tout autour du jeu, y compris l'espace situé au-dessus de ce dernier. L'ajout d'accessoires est susceptible d'étendre cette aire de sécurité. La surface au sol doit être bien plane. Installé sur un terrain en pente, ce jeu pourra pencher ou s'endommager. Les composants seront alors soumis à des tensions plus importantes, ce qui risque de diminuer leur durée de vie. L'aire de sécurité ne doit pas comporter de structures, aménagements paysagers, arbres et branches, pierres, câbles, têtes d'arrosage ou autres obstacles susceptibles d'empêcher les enfants de jouer en toute sécurité. Les enfants pourraient heurter ces obstacles en courant ou en se balançant et ainsi se blesser grièvement.

Area di gioco sicura raccomandata:

L'Area di giuoco sicura si riferisce alla zona che si estende per 2 m su tutti i lati oltre l'insieme da gioco, incluso lo spazio al di sopra dell'apparato. Gli accessori aggiuntivi possono estendere le dimensioni dell'Area di gioco sicura. La superficie del terreno deve essere in pari. Installando l'insieme da gioco sul terreno in pendenza, può inclinarsi o 'stirarsi'. Ciò sottoporrebbe tutti i componenti a sforzo addizionale, e potrebbe comprometterne la durata. L'Area di gioco sicura deve essere libera da strutture, variazioni del terreno, alberi e rami, pietre, fili metallici, testine per annaffiare e tutto quanto esporrebbe a rischio la sicurezza del gioco. Correndo contro questi ostacoli, o urtandovi durante l'oscillazione, i bambini potrebbero ferirsi seriamente.

Área Segura de Juego recomendada:

El Área Segura de Juego se refiere a la zona que se extiende hasta 2m desde los juegos todo alrededor, incluyendo el espacio encima del aparato. Accesorios adicionales pueden aumentar el tamaño del Área Segura de Juego. La superficie del suelo debe ser uniforme. Si instala sus juegos sobre un terreno con declive, har- que se inclinen o se "arruinen". Esto coloca tensión adicional sobre todos los componentes y puede acortar su vida útil. El Área Segura de Juego debe estar libre de todo tipo de estructuras, arquitectura paisajista, árboles y ramas, rocas, cables, boquillas de aspersores y cualquier otro elemento que pueda obstaculizar el juego seguro. Los niños pueden herirse gravemente con estos obstáculos al correr o columpiarse.

Empfohlene sichere Spielfläche:

Die sichere Spielfläche erstreckt sich an allen Seiten 2 m über das Spielgerät hinaus, einschließlich Raum über dem Gerät. Zubehör kann die sichere Spielfläche erweitern. Der Boden muss eben sein. Wenn Sie das Spielgerät auf einem Hang installieren, kann es sich lehnen oder verziehen. Dadurch werden alle Teile zusätzlicher Last ausgesetzt, was zu verkürzter Lebensdauer führen kann. Im sicheren Spielraum darf sich nichts befinden, das sicheres Spielen behindern könnte wie z.B. Aufbauten, Gärten, Bäume oder Büsche, Steine, Draht, Rasensprinkler oder ähnliches. Wenn Kinder in solche Hindernisse hineinlaufen oder -schaukeln, können sie sich schwer verletzen.

Área de Actividades Segura Recomendada

A Área de Actividades Segura Recomendada refere-se à zona que se estende por 2 m em todas as direções à volta dos elementos de diversão, incluindo o espaço acima dos mesmos. Acessórios adicionais poderão aumentar o tamanho da Área de Actividades Segura. A superfície do terreno deve ser nivelada. A instalação do parque infantil em terreno com declives pode fazer com que este fique inclinado ou "deformado". Isto coloca tensão adicional em todas as ligações e juntas e, com o passar do tempo, faz com que estas cedam. Para que a Área de Actividades seja segura, não deverá haver outras estruturas, áreas ajardinadas, árvores e ramos, rochas, fios, aspersores ou outros obstáculos semelhantes à superfície. As crianças poderão sofrer graves ferimentos pessoais se, ao correrem ou baloiçarem, caírem de encontro a estes elementos.

28

FB3041 **x2**
Sandpit Liner

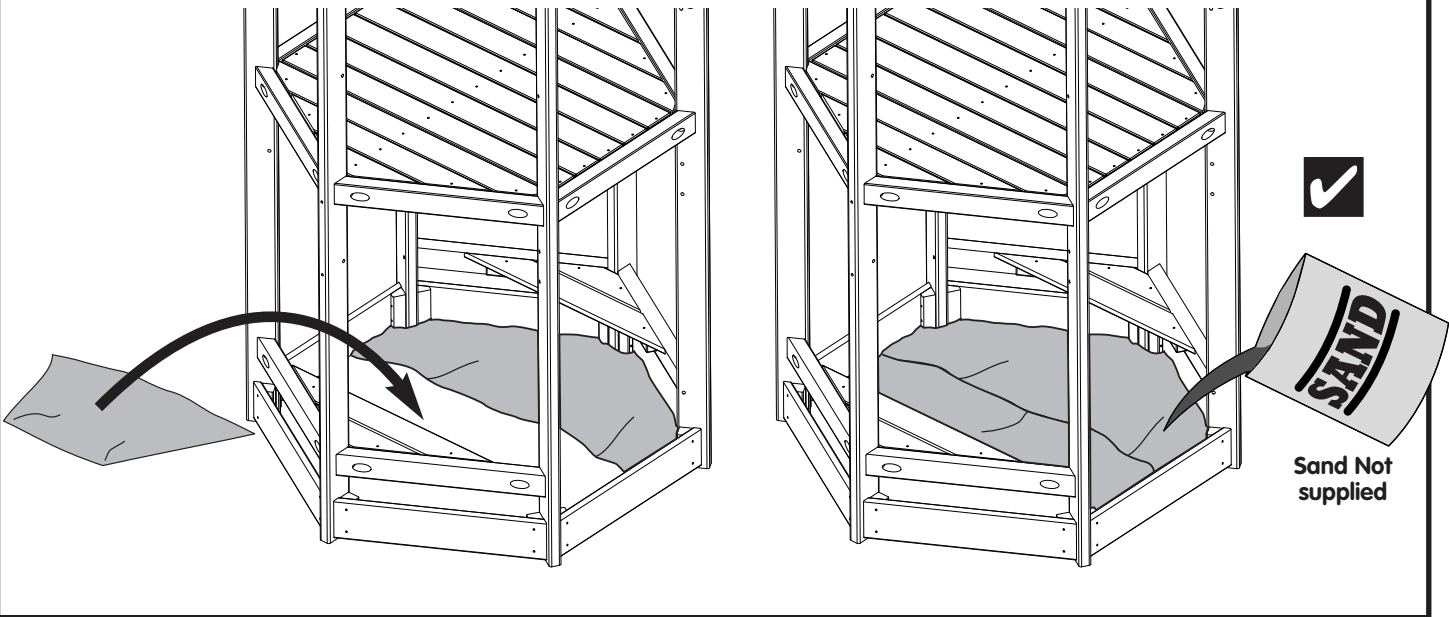
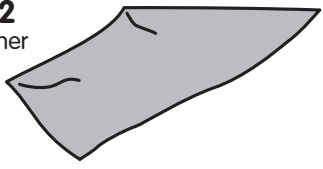

29

PR5069 **x3**

FA8380
M8 x 40mm
Coach screw
x3

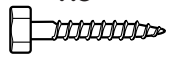

FA7184
M8 Washer
(25mm o/dia)
x3

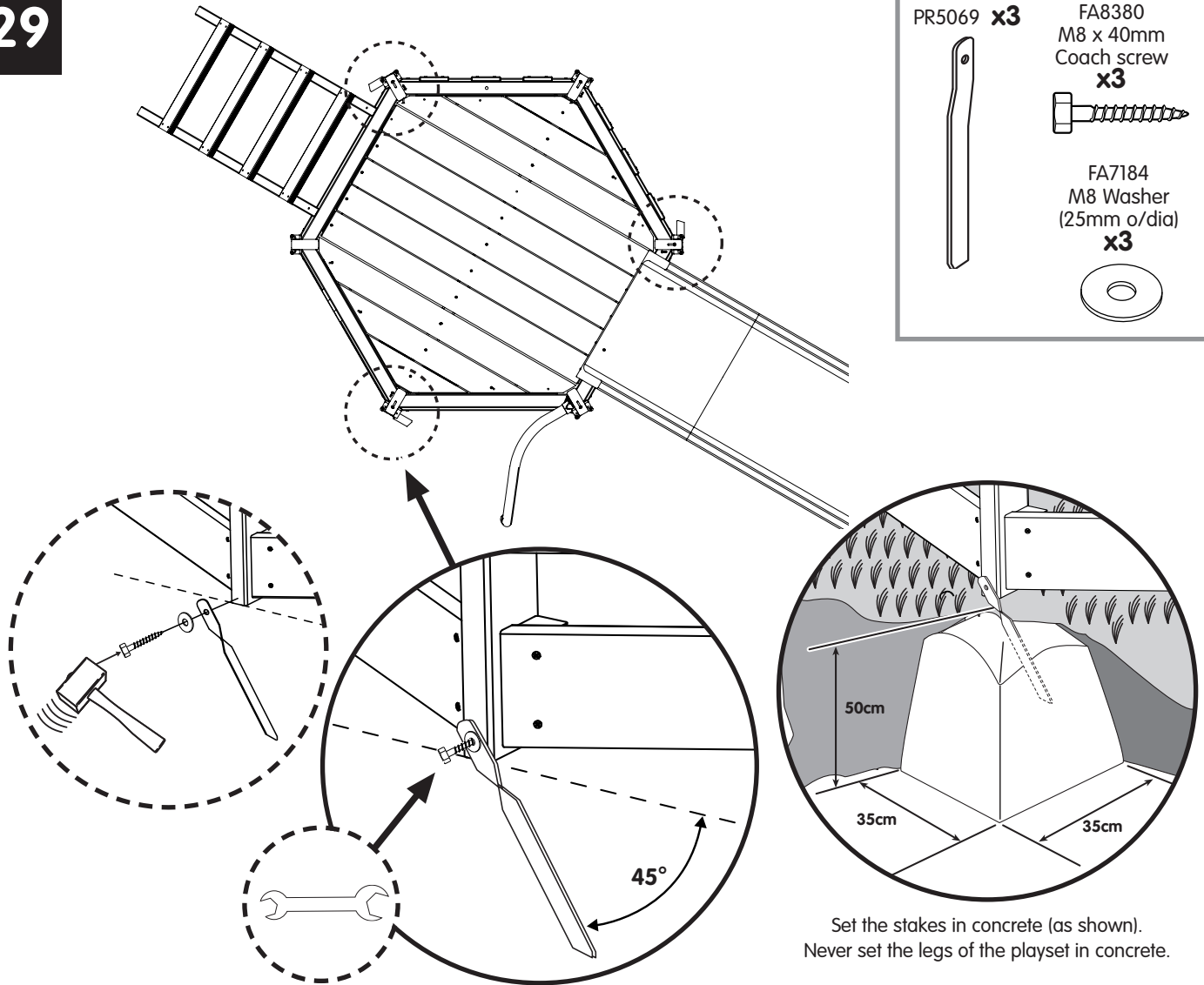

Set the stakes in concrete (as shown).
Never set the legs of the playset in concrete.

30

PM8294
12mm Plug
x20

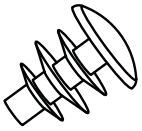

Build Option **A**
TP969 CrazyWavy Slide

Build Option **B**
TP968 Wavy Slide

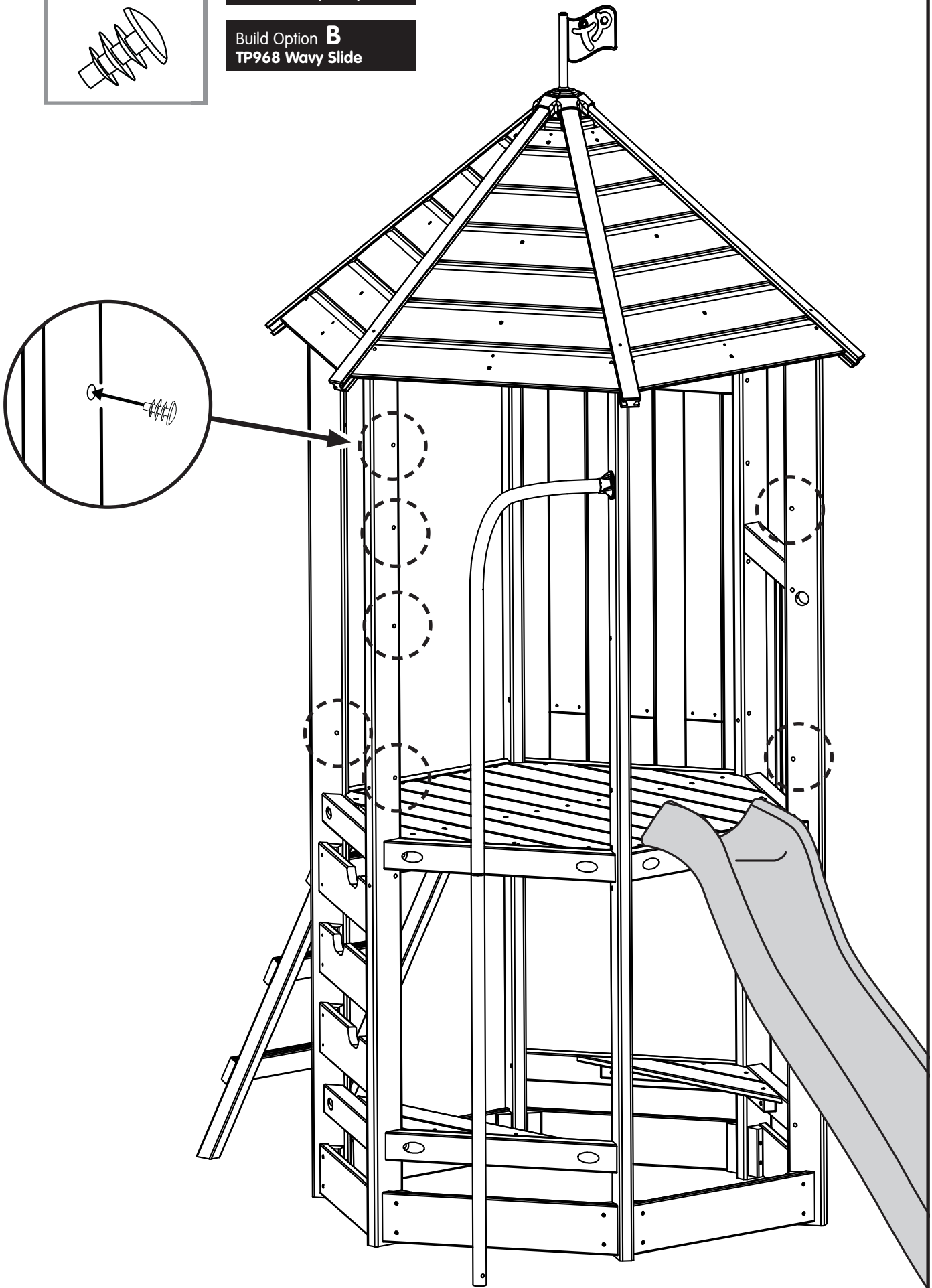



Register your new TP product on line now at www.tptoys.com/product registration

Thank you for purchasing this TP product. To find out all about your product guarantee and register your purchase, please visit www.tptoys.com/productregistration.

We want to give you the very best service. By registering your purchase now, we will be able to deal with any guarantee issues very quickly and efficiently in the future. Thank you.

Your TP Guarantee Number/Product Batch No is

Designed in the UK by **Robovision Ltd t/as TP Toys**
Unit 11, Enterprise Way, Flitwick, Bedfordshire, MK45 5BX.
Made in England.

www.tptoys.com